

AIRSPEC ROOTS COMPRESSOR / VACUUM PUMP



3-LOBE ROOTS COMPRESSOR

Airspec is the first professional manufacturer for 3-lobe Roots Compressor in Taiwan, with our diligence, faith and honor for developing Roots Compressor, we have the high pressure water cooled blowers, the submersible blowers, EV-Series high efficiency blowers, the high pressure roots vacuum pump with air injection, booster and vertical blower.

FEATURES

1. Wide range of capacity, pressure, vacuum
Bore size : 32 mm ~ 400 mm (1-1/4"~ 14")
Capacity : 0.3 ~ 278 m³/min (8 ~ 9800 CFM)
Pressure :
RSS up to 8000 mmAq (0.8 Kg/cm²)
RSW up to 10000 mmAq (1 Kg/cm²)
TRS(2 stage type) up to 20000 mmAq (2 Kg/cm²)
Vacuum :
1 stage up to -500 mmHg
2 stage up to -600 mmHg
high pressure roots up to -700 mmHg
2. Blowed air without oil
3. Computerized balance to lower noise level and vibration
4. Steady blow, steady capacity
5. Rotor of special design, high efficiency, low consumption
6. Solid construction, no defect
7. First degree gear, high precision, low consumption
8. Standardized processing system
9. One step process for rotor
10. Piston ring installed

The difference between Roots Compressor of 2 lobes and 3 lobes

Traditional 2 lobes Roots Compressor has high vibration and noise level, this causes short life of parts.

THE ADVANTAGE OF 3-LOBE ROOTS COMPRESSOR

1. Low revers pressure, steady capacity, low vibration, low noise level
2. Low fluctuation of outlet pressure, make long life of bearing, gear
3. In the same RPM, 3-lobe Roots Compressor has low noise level, low vibration, longer life

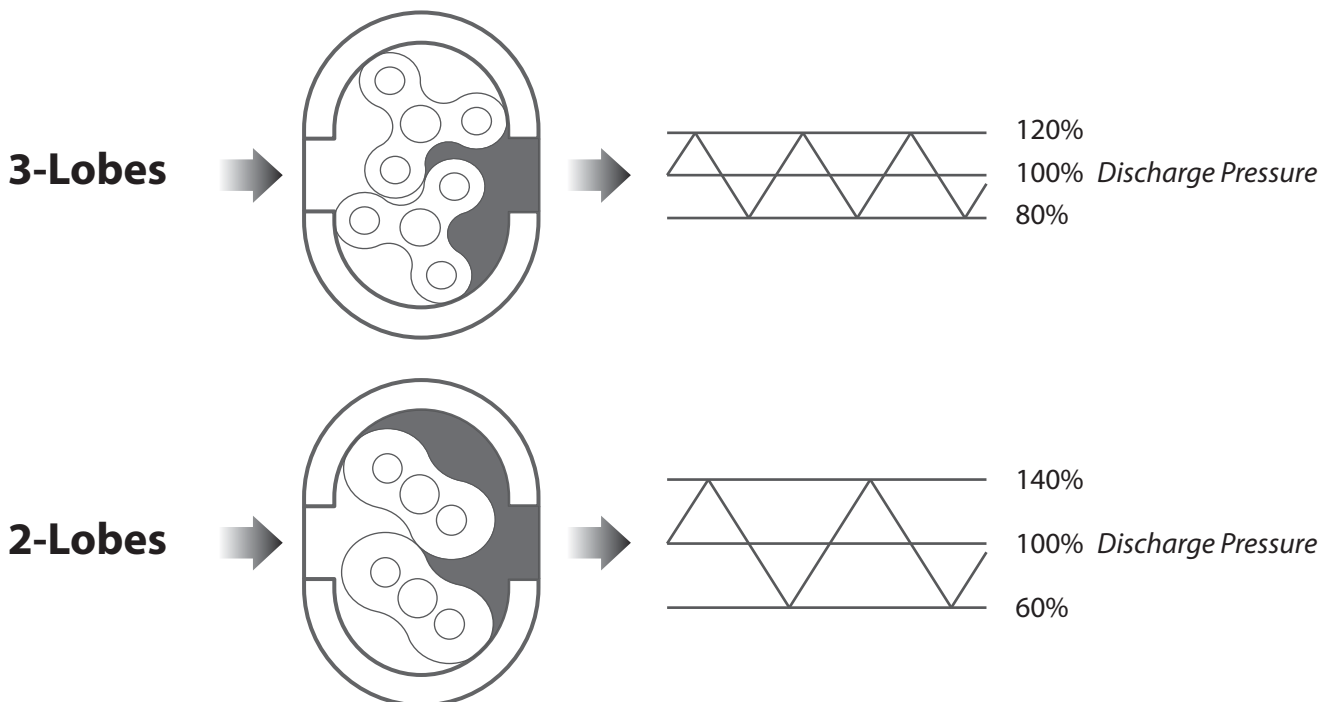

ASS PARTS LIST

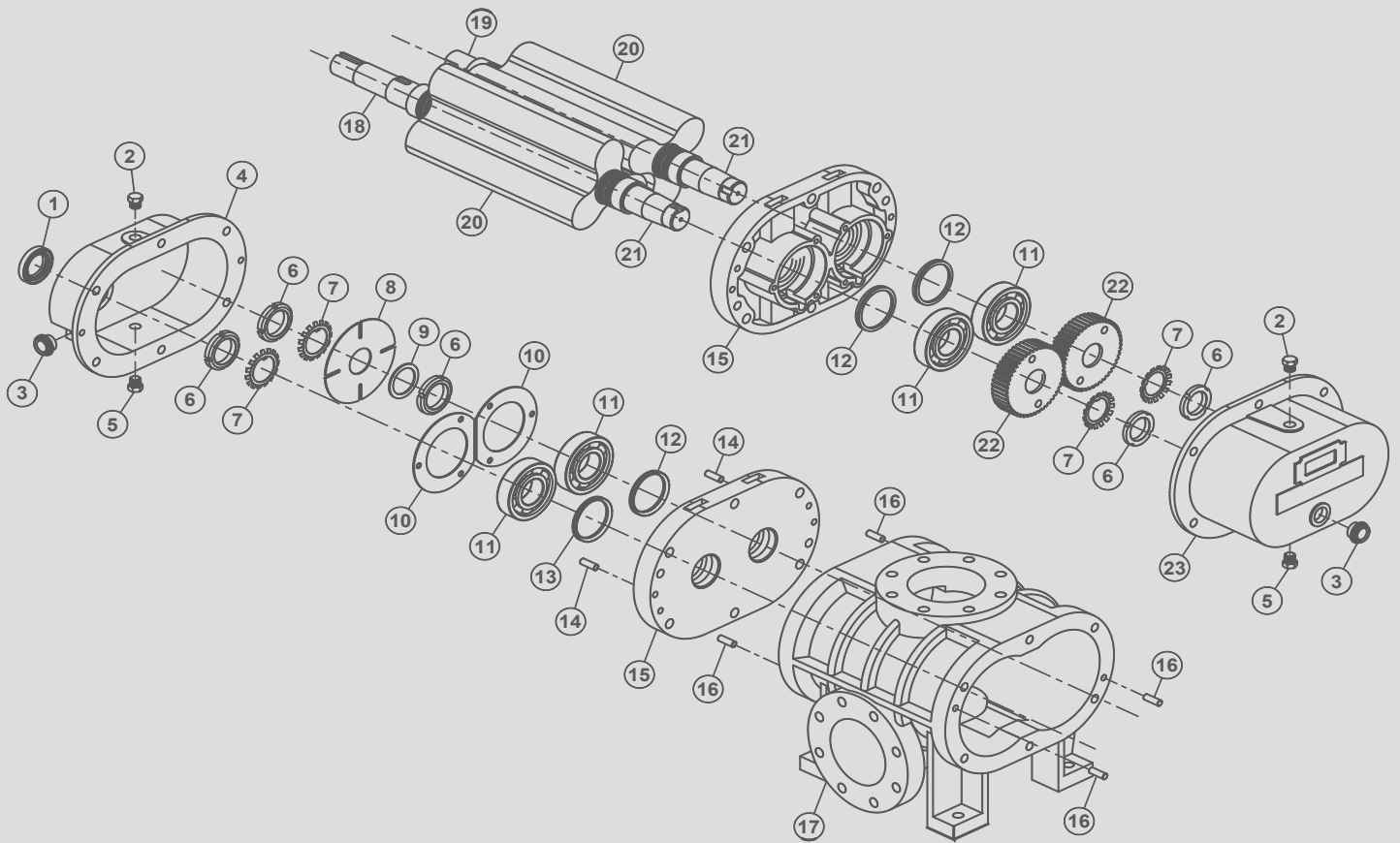

NO.	NAME	MATERIAL	QTY	NO.	NAME	MATERIAL	QTY
1	TC Oil seal	NBR	1	16	Positioning pins	S45C	4
2	Lubricant plug	ABS	2	17	Blower casing	FC250	1
3	Oil sight window	Glass	2	18	Drive shaft	SCM440	1
4	Oil reservoir	FC250	1	19	Driven shaft	SCM440	1
5	Purge plug	S45C	2	20	Rotors	FC250	2
6	Locking nuts	S45C	5	21	Gear Shaft	SCM440	2
7	Lock washer	S45C	4	22	Timing gears	SNCM220	2
8	Oil thrower	SS400	1	23	Oil reservoir	FC250	1
9	Oil thrower washer	SS400	1				
10	Bearing fixtures	SS400	2				
11	Bearings	SUJ2	4				
12	V-ring	Viton	3				
13	TC Oil seal	NBR	1				
14	Positioning pins	S45C	2				
15	Bearing case	FC250	2				

ASS MAIN-BODY DIMENSION

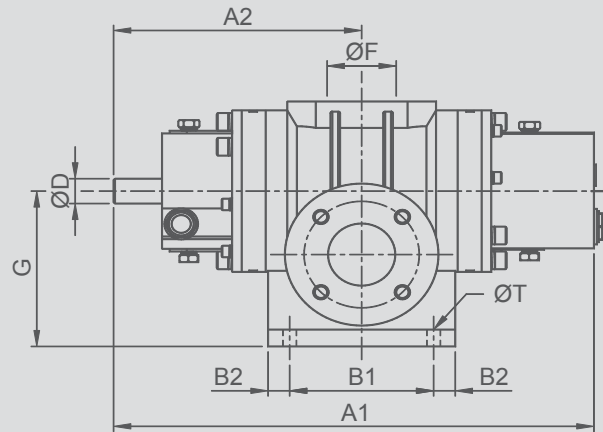
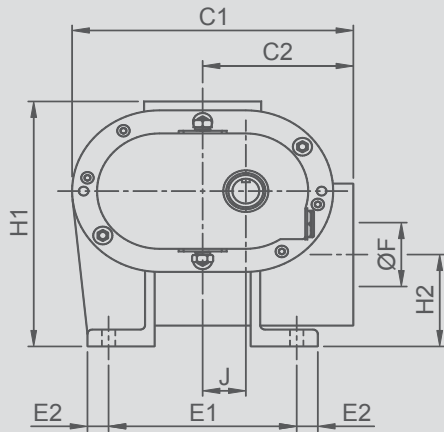

Model	A1	A2	B1	B2	C1	C2	ØD	ØT	E1	E2	ØF	G	H1	H2	J	Wt.(kg)
ASS-40	421	219	80	15	276	140	28	14	196	22	JIS 5K 1½" / 10K 2"	180	285	104	45	55
ASS-50	501	259	150	22.5	276	140	28	14	196	22	JIS 10K 2"	191	292	104	45	70
ASS-65	561	289	196	27	288	152	28	14	196	27	JIS 10K 2.5"	194	295	104	45	72
ASS-80	640	343	196	22	358	180	38	14	196	22	JIS 10K 3"	212	341	107	60	136
ASS-100	740	393	282	24	358	180	38	14	232	29	JIS 10K 4"	217	352	112	60	148
ASS-125A	770	400	210	20	483	250	48	19	346	27	JIS 10K 5"	262	430	135	80	248
ASS-125	890	460	310	30	483	250	48	19	355	22.5	JIS 10K 5"	262	430	163	80	274
ASS-150	1000	515	428	26	483	250	48	19	355	22.5	JIS 10K 6"	289	453	163	80	308
ASS-200A	993	495	239	45.5	700	360	65	23	555	42.5	JIS 10K 8"	402	630	198	120	640
ASS-200	1093	545	400	38	690	350	65	23	550	35	JIS 10K 8"	402	630	198	120	732
ASS-250	1243	620	520	25	700	360	65	23	550	35	JIS 10K 10"	435	660	218	120	929
ASS-300A	1479	756	680	45	700	360	75	23	540	40	JIS 10K 12"	435	675	255	120	1071
ASS-300	1306	699	420	55	1010	510	95	33	780	35	JIS 10K 12"	550	880	300	180	1700
ASS-350	1626	859	740	55	1010	510	95	33	780	35	JIS 10K 14"	550	880	300	180	2250
ASS-400	1766	929	880	55	1010	510	95	33	780	35	JIS 10K 16"	550	880	300	180	2500

ASS-32

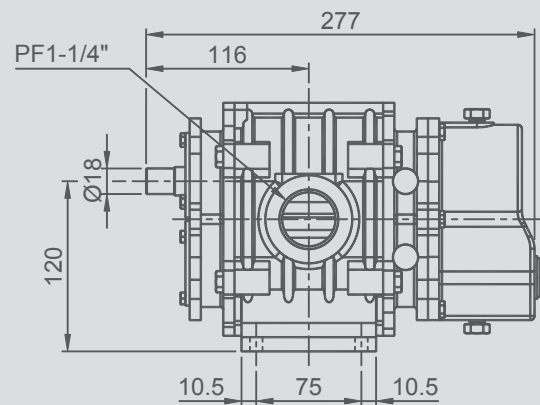
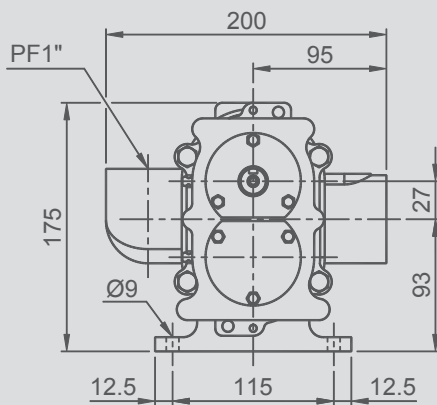

Model	A1	A2	B1	B2	C1	C2	ØD	ØT	E1	E2	ØF	G	H1	H2	J	Wt.(kg)
RSS-32	277	116	75	10.5	200	95	18	9	115	12.5	1"PF / ¼"PF	120	175	93	27	17

ASS OVERALL DIMENSION

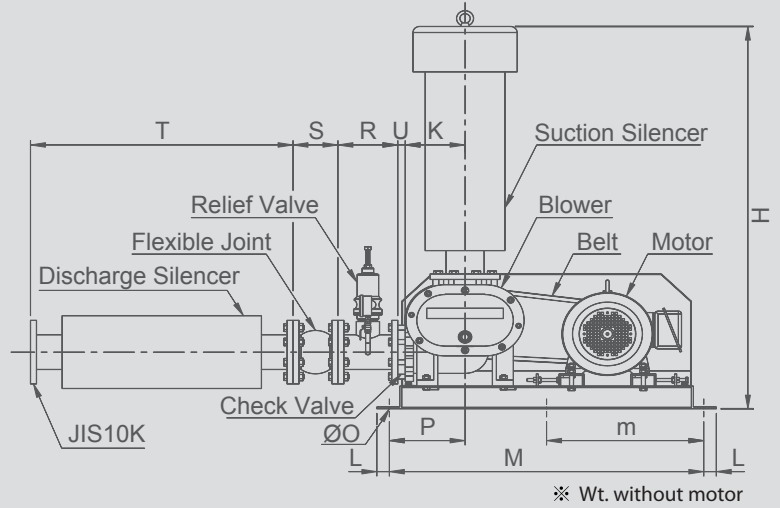
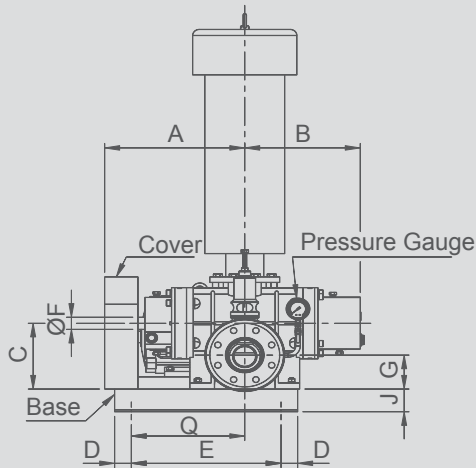

Model	A	B	C	D	E	ØF	G	H	J	K	L	M	m	ØO	P	Q	R	U	S	T	Wt.(kg)
ASS-40	235	202	180	20	350	28	104	731	46	140	50	500	-	14	98	255	150	20	105	589	85
ASS-50	274	242	191	50	350	28	104	933	75	140	37.5	795	-	12.7	208	209	150	20	105	589	122
ASS-65	303	272	194	50	350	28	104	936	75	152	37.5	795	-	12.7	208	238	150	24	115	589	132
ASS-80	371	297	212	50	450	38	107	1251	75	180	37.5	945	-	12.7	228	291	180	24	136	789	233
ASS-100	421	347	217	50	450	38	112	1262	75	180	37.5	945	-	12.7	228	341	180	22	136	789	247
ASS-125A	435	371	262	25	550	48	135	1851	100	250	100	900	-	19	133	240	250	24	174	1260	408
ASS-125	495	431	262	25	550	48	163	1851	100	250	100	900	-	19	138	300	250	24	174	1260	434
ASS-150	536	486	289	25	550	48	163	1874	100	250	100	900	-	19	138	341	250	26	180	1260	485
ASS-200A	560	498	402	32.5	935	65	198	2263	125	360	100	1300	650	20	313	352	250	27	205	1640	990
ASS-200	610	548	402	32.5	935	65	198	2263	125	350	100	1300	650	20	313	403	250	27	205	1640	1080
ASS-250	685	623	435	32.5	935	65	218	2500	125	360	100	1300	650	20	313	478	250	28	240	1760	1350
ASS-300A	800	723	435	37.5	925	75	255	2682	150	360	235	1530	765	24	273	523	300	32	260	1750	1660
ASS-300	780	607	550	45	1010	95	300	3097	250	510	235	2000	1000	33	325	400	300	32	260	1850	2500
ASS-350	940	767	550	45	1110	95	300	3367	250	510	235	2000	1000	33	325	560	350	35	265	2500	3380
ASS-400	1020	837	550	45	1110	95	300	3663	250	510	235	2000	1000	33	325	670	350	40	265	2700	3850

ASS-32

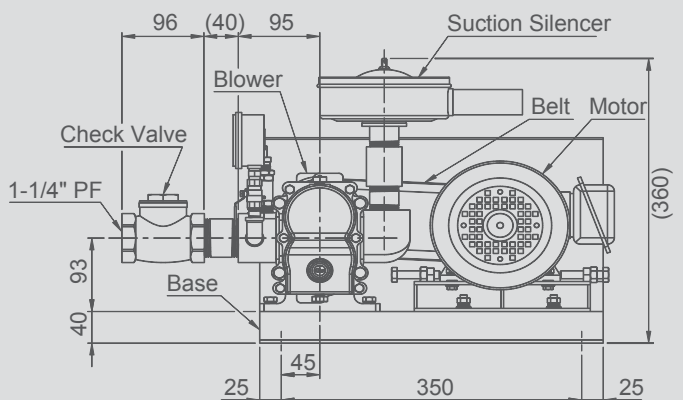
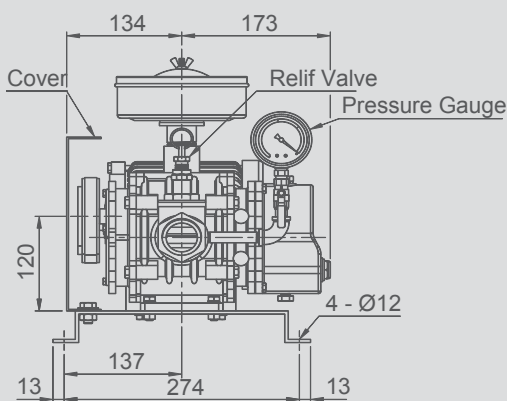

Model	A	B	C	D	E	ØF	G	H	J	K	L	M	m	ØO	P	Q	R	U	S	T	Wt.(kg)
ASS-32	134	173	120	13	274	18	93	360	40	95	25	350	-	12	45	137	40	96	-	-	28

ASS PERFORMANCE TABLE

NOTE: inlet flow rate Qs=m³/min

Model	RPM	TYPE ASS-32 PERFORMANCE															
		1000mmAq		2000mmAq		3000mmAq		4000mmAq		5000mmAq		6000mmAq		7000mmAq		8000mmAq	
		Qs	kw	Qs	kw	Qs	kw	Qs	kw	Qs	kw	Qs	kw	Qs	kw	Qs	kw
ASS-32	1500	0.50	0.26	0.46	0.34	0.42	0.42	0.38	0.50	0.34	0.58	0.30	0.66	-	-	-	-
	1750	0.58	0.31	0.54	0.40	0.49	0.49	0.45	0.58	0.41	0.67	0.37	0.76	-	-	-	-
	2000	0.66	0.35	0.61	0.46	0.56	0.56	0.51	0.66	0.46	0.77	0.41	0.87	-	-	-	-
	2300	0.76	0.40	0.70	0.52	0.64	0.64	0.58	0.76	0.52	0.88	0.46	1.00	-	-	-	-
	2600	0.88	0.64	0.82	0.76	0.76	0.88	0.70	1.00	0.64	1.12	0.58	1.24	-	-	-	-
	3000	1.02	0.92	0.96	1.04	0.90	1.16	0.84	1.28	0.78	1.40	0.72	1.52	-	-	-	-

Model	RPM	TYPE ASS-40 PERFORMANCE															
		1000mmAq		2000mmAq		3000mmAq		4000mmAq		5000mmAq		6000mmAq		7000mmAq		8000mmAq	
		Qs	kw	Qs	kw	Qs	kw	Qs	kw	Qs	kw	Qs	kw	Qs	kw	Qs	kw
ASS-40	850	1.02	0.23	0.85	0.47	0.67	0.70	0.46	0.94	0.23	1.17	-	-	-	-	-	-
	950	1.18	0.26	1.01	0.53	0.83	0.79	0.64	1.05	0.44	1.31	-	-	-	-	-	-
	1050	1.33	0.29	1.16	0.58	0.99	0.87	0.81	1.16	0.62	1.45	-	-	-	-	-	-
	1150	1.49	0.32	1.32	0.64	1.14	0.95	0.95	1.27	0.76	1.59	-	-	-	-	-	-
	1250	1.64	0.35	1.47	0.69	1.30	1.04	1.14	1.38	0.98	1.73	0.82	2.07	0.67	2.42	0.52	2.76
	1350	1.80	0.37	1.62	0.75	1.46	1.12	1.31	1.49	1.17	1.87	1.04	2.24	0.93	2.61	0.82	2.99
	1450	1.96	0.40	1.78	0.80	1.61	1.20	1.47	1.60	1.35	2.00	1.26	2.40	1.17	2.81	1.11	3.21
	1550	2.11	0.43	1.93	0.86	1.77	1.29	1.63	1.71	1.51	2.14	1.41	2.57	1.33	3.00	1.26	3.43
	1650	2.27	0.46	2.08	0.91	1.92	1.37	1.78	1.82	1.66	2.28	1.57	2.74	1.48	3.19	1.42	3.65
	1750	2.42	0.48	2.24	0.97	2.08	1.45	1.94	1.93	1.82	2.42	1.72	2.90	1.64	3.39	1.57	3.87
	1850	2.58	0.51	2.39	1.02	2.23	1.53	2.09	2.05	1.97	2.56	1.88	3.07	1.79	3.58	1.73	4.09
	1950	2.73	0.54	2.55	1.08	2.39	1.62	2.25	2.16	2.13	2.70	2.03	3.23	1.95	3.77	1.88	4.31

Model	RPM	TYPE ASS-50 PERFORMANCE															
		1000mmAq		2000mmAq		3000mmAq		4000mmAq		5000mmAq		6000mmAq		7000mmAq		8000mmAq	
		Qs	kw	Qs	kw	Qs	kw	Qs	kw	Qs	kw	Qs	kw	Qs	kw	Qs	kw
ASS-50	850	1.60	0.44	1.37	0.87	1.18	1.29	1.02	1.70	0.88	2.09	0.76	2.48	0.67	2.86	0.60	3.06
	950	1.87	0.50	1.64	0.98	1.45	1.44	1.29	1.90	1.15	2.34	1.03	2.78	0.94	3.19	0.87	3.61
	1050	2.13	0.55	1.90	1.08	1.71	1.60	1.55	2.10	1.41	2.59	1.29	3.06	1.20	3.53	1.13	3.99
	1150	2.40	0.60	2.17	1.19	1.98	1.75	1.82	2.30	1.68	2.84	1.56	3.36	1.47	3.87	1.40	4.37
	1250	2.67	0.66	2.44	1.29	2.25	1.90	2.09	2.50	1.95	3.08	1.83	3.65	1.74	4.21	1.67	4.75
	1350	2.93	0.71	2.70	1.39	2.51	2.06	2.35	2.70	2.21	3.33	2.09	3.94	2.00	4.54	1.93	5.13
	1450	3.20	0.76	2.97	1.50	2.78	2.21	2.62	2.90	2.48	3.57	2.36	4.23	2.27	4.88	2.20	5.51
	1550	3.47	0.81	3.24	1.60	3.05	2.36	2.89	3.10	2.75	3.82	2.63	4.52	2.54	5.22	2.47	5.89
	1650	3.74	0.86	3.51	1.70	3.32	2.51	3.16	3.30	3.02	4.07	2.90	4.82	2.81	5.55	2.74	6.27
	1750	4.01	0.91	3.78	1.80	3.59	2.66	3.43	3.50	3.29	4.31	3.17	5.11	3.08	5.89	3.01	6.65
	1850	4.28	0.97	4.05	1.91	3.86	2.82	3.70	3.70	3.56	4.56	3.44	5.40	3.35	6.23	3.28	7.03
	1950	4.55	1.02	4.32	2.01	4.13	2.97	3.97	3.90	3.83	4.80	3.71	5.69	3.62	6.56	3.55	7.41

Model	RPM	TYPE ASS-65 PERFORMANCE															
		1000mmAq		2000mmAq		3000mmAq		4000mmAq		5000mmAq		6000mmAq		7000mmAq		8000mmAq	
		Qs	kw	Qs	kw	Qs	kw	Qs	kw	Qs	kw	Qs	kw	Qs	kw	Qs	kw
ASS-65	850	2.17	0.61	1.99	1.20	1.80	1.76	1.63	2.30	1.49	2.81	1.36	3.31	1.25	3.79	1.15	4.26
	950	2.53	0.69	2.35	1.35	2.16	1.96	1.99	2.57	1.85	3.14	1.72	3.70	1.60	4.24	1.51	4.76
	1050	2.88	0.75	2.70	1.48	2.51	2.17	2.34	2.84	2.20	3.47	2.07	4.09	1.96	4.69	1.86	5.27
	1150	3.24	0.83	3.06	1.62	2.87	2.37	2.70	3.10	2.56	3.80	2.43	4.48	2.32	5.14	2.22	5.77
	1250	3.60	0.90	3.42	1.77	3.23	2.58	3.06	3.38	2.92	4.13	2.79	4.87	2.68	5.58	2.58	6.27
	1350	3.96	0.97	3.78	1.91	3.59	2.79	3.42	3.65	3.28	4.46	3.15	5.26	3.04	6.03	2.94	6.77
	1450	4.32	1.05	4.14	2.04	3.95	3.00	3.78	3.92	3.64	4.79	3.51	5.65	3.40	6.47	3.30	7.27
	1550	4.68	1.12	4.50	2.19	4.31	3.21	4.14	4.19	4.00	5.12	3.87	6.04	3.76	6.92	3.66	7.77
	1650	5.04	1.19	4.86	2.33	4.67	3.41	4.50	4.46	4.36	5.46	4.23	6.43	4.12	7.37	4.02	8.27
	1750	5.40	1.26	5.22	2.47	5.03	3.62	4.86	4.73	4.72	5.79	4.59	6.82	4.48	7.82	4.38	8.77
	1850	5.76	1.34	5.58	2.61	5.39	3.83	5.22	5.00	5.08	6.12	4.95	7.21	4.84	8.26	4.74	9.28
	1950	6.12	1.41	5.94	2.76	5.75	4.04	5.58	5.27	5.44	6.45	5.31	7.60	5.20	8.71	5.10	9.79

ASS PERFORMANCE TABLE

NOTE: inlet flow rate Qs=m³/min

Model	RPM	TYPE ASS-80 PERFORMANCE															
		1000mmAq		2000mmAq		3000mmAq		4000mmAq		5000mmAq		6000mmAq		7000mmAq		8000mmAq	
		Qs	kw	Qs	kw	Qs	kw	Qs	kw	Qs	kw	Qs	kw	Qs	kw	Qs	kw
ASS-80	800	3.83	1.09	3.38	2.08	2.98	2.99	2.62	3.82	2.31	4.59	2.03	5.31	1.79	5.97	1.57	6.70
	900	4.43	1.22	3.98	2.34	3.58	3.36	3.22	4.30	2.91	5.17	2.63	5.97	2.39	6.72	2.17	7.52
	1000	5.03	1.36	4.58	2.60	4.19	3.73	3.82	4.77	3.51	5.74	3.23	6.63	2.99	7.47	2.77	8.35
	1100	5.63	1.49	5.18	2.85	4.79	4.11	4.43	5.25	4.12	6.32	3.83	7.30	3.59	8.21	3.37	9.17
	1200	6.23	1.63	5.78	3.11	5.39	4.48	5.03	5.73	4.72	6.89	4.43	7.96	4.19	8.96	3.97	9.99
	1300	6.83	1.76	6.38	3.37	5.99	4.85	5.63	6.21	5.32	7.47	5.03	8.62	4.79	9.70	4.57	10.82
	1400	7.43	1.90	6.98	3.63	6.59	5.23	6.23	6.69	5.92	8.04	5.64	9.29	5.39	10.45	5.17	11.64
	1500	8.03	2.03	7.58	3.89	7.19	5.60	6.83	7.17	6.52	8.61	6.24	9.95	5.99	11.20	5.77	12.46
	1600	8.63	2.17	8.18	4.15	7.79	5.97	7.43	7.64	7.12	9.19	6.84	10.61	6.59	11.94	6.37	13.29
	1650	8.93	2.24	8.48	4.28	8.09	6.16	7.73	7.88	7.42	9.47	7.14	10.95	6.89	12.32	6.67	13.70
	1750	9.53	2.38	9.09	4.54	8.69	6.53	8.33	8.36	8.02	10.04	7.74	11.61	7.49	13.06	7.27	14.52
	1850	10.13	2.52	9.69	4.80	9.29	6.90	8.93	8.83	8.62	10.62	8.34	12.28	8.09	13.81	7.87	15.34
	1950	10.73	2.65	10.29	5.06	9.89	7.28	9.53	9.31	9.22	11.19	8.94	12.94	8.69	14.56	8.47	16.16

Model	RPM	TYPE ASS-100 PERFORMANCE															
		1000mmAq		2000mmAq		3000mmAq		4000mmAq		5000mmAq		6000mmAq		7000mmAq		8000mmAq	
		Qs	kw	Qs	kw	Qs	kw	Qs	kw	Qs	kw	Qs	kw	Qs	kw	Qs	kw
ASS-100	800	5.40	1.40	4.80	2.75	4.26	3.89	3.78	5.05	3.36	6.05	2.99	6.96	2.66	7.89	2.38	8.92
	900	6.25	1.59	5.64	3.09	5.11	4.40	4.62	5.67	4.21	6.81	3.83	7.87	3.51	8.92	3.22	10.01
	1000	7.09	1.78	6.49	3.42	5.95	4.90	5.47	6.30	5.05	7.56	4.68	8.79	4.35	9.95	4.07	11.11
	1100	7.94	1.97	7.33	3.76	6.80	5.40	6.31	6.93	5.90	8.35	5.52	9.70	5.20	10.98	4.91	12.21
	1200	8.78	2.16	8.18	4.10	7.64	5.91	7.16	7.56	6.74	9.13	6.37	10.61	6.04	12.02	5.76	13.32
	1300	9.63	2.35	9.02	4.44	8.49	6.41	8.00	8.19	7.59	9.92	7.21	11.53	6.89	13.05	6.60	14.42
	1400	10.47	2.52	9.87	4.77	9.33	6.87	8.85	8.81	8.43	10.66	8.06	12.40	7.73	14.01	7.45	15.54
	1500	11.32	2.69	10.71	5.10	10.18	7.34	9.69	9.44	9.28	11.41	8.90	13.27	8.58	14.97	8.29	16.66
	1600	12.16	2.86	11.56	5.44	11.02	7.81	10.54	10.06	10.12	12.16	9.75	14.15	9.42	15.93	9.14	17.79
	1650	12.59	2.95	11.98	5.61	11.45	8.05	10.96	10.37	10.55	12.55	10.17	14.57	9.85	16.43	9.56	18.37
	1750	13.43	3.13	12.83	5.96	12.29	8.55	11.81	11.01	11.39	13.32	11.02	15.41	10.69	17.44	10.41	19.52
	1850	14.28	3.30	13.67	6.30	13.14	9.04	12.65	11.65	12.24	14.08	11.86	16.24	11.54	18.45	11.25	20.67
	1950	15.12	3.48	14.52	6.65	13.98	9.53	13.50	12.28	13.08	14.85	12.71	17.08	12.38	19.45	12.10	21.85

Model	RPM	TYPE ASS-125A PERFORMANCE															
		1000mmAq		2000mmAq		3000mmAq		4000mmAq		5000mmAq		6000mmAq		7000mmAq		8000mmAq	
		Qs	kw	Qs	kw	Qs	kw	Qs	kw	Qs	kw	Qs	kw	Qs	kw	Qs	kw
ASS-125A	780	7.96	1.93	7.30	3.71	6.68	5.35	6.11	6.84	5.65	8.24	5.19	9.52	4.76	10.71	4.39	11.83
	830	8.55	2.06	7.88	3.95	7.27	5.69	6.69	7.28	6.23	8.76	5.77	10.13	5.34	11.40	4.97	12.59
	880	9.13	2.18	8.46	4.19	7.85	6.03	7.28	7.72	6.81	9.29	6.35	10.74	5.92	12.09	5.56	13.35
	930	9.71	2.31	9.04	4.43	8.43	6.38	7.86	8.17	7.40	9.82	6.94	11.35	6.51	12.78	6.14	14.11
	990	10.41	2.46	9.74	4.72	9.13	6.79	8.56	8.69	8.10	10.46	7.64	12.08	7.21	13.61	6.84	15.02
	1050	11.11	2.61	10.44	5.00	9.83	7.20	9.26	9.22	8.79	11.09	8.33	12.82	7.91	14.43	7.54	15.93
	1110	11.81	2.76	11.14	5.29	10.53	7.62	9.96	9.75	9.49	11.72	9.03	13.55	8.61	15.26	8.24	16.84
	1180	12.63	2.93	11.96	5.62	11.35	8.10	10.78	10.37	10.31	12.47	9.85	14.41	9.43	16.22	9.06	17.90
	1250	13.45	3.10	12.78	5.96	12.16	8.58	11.60	10.98	11.13	13.21	10.67	15.26	10.24	17.18	9.88	18.97
	1320	14.27	3.28	13.59	6.29	12.98	9.06	12.41	11.60	11.95	13.95	11.48	16.12	11.06	18.15	10.69	20.03
	1390	15.08	3.45	14.41	6.63	13.79	9.54	13.23	12.22	12.76	14.69	12.30	16.98	11.88	19.11	11.51	21.09
	1470	16.02	3.65	15.34	7.01	14.73	10.09	14.16	12.92	13.70	15.54	13.24	17.96	12.81	20.21	12.44	22.31
	1560	17.07	3.88	16.39	7.44	15.78	10.71	15.21	13.71	14.75	16.49	14.29	19.06	13.86	21.45	13.49	23.67
	1650	18.12	4.11	17.44	7.87	16.83	11.33	16.27	14.51	15.80	17.44	15.34	20.16	14.91	22.69	14.54	25.04
	1750	19.28	4.36	18.61	8.35	18.00	12.02	17.43	15.39	16.96	18.50	16.50	21.38	16.08	24.07	15.71	26.56
1850	20.45	4.61	19.78	8.82	19.16	12.70	18.60	16.27	18.13	19.56	17.67	22.60	17.25	25.45	16.87	28.08	

ASS PERFORMANCE TABLE

NOTE: inlet flow rate Qs=m³/min

Model	RPM	TYPE ASS-125 PERFORMANCE															
		1000mmAq		2000mmAq		3000mmAq		4000mmAq		5000mmAq		6000mmAq		7000mmAq		8000mmAq	
		Qs	kw	Qs	kw	Qs	kw	Qs	kw	Qs	kw	Qs	kw	Qs	kw	Qs	kw
ASS-125	780	11.44	2.85	10.43	5.42	9.56	7.78	8.81	9.97	8.19	12.06	7.68	14.12	7.30	16.31	6.99	18.48
	830	12.31	3.04	11.31	5.79	10.44	8.30	9.70	10.66	9.07	12.88	8.56	15.07	8.16	17.31	7.87	19.60
	880	13.19	3.23	12.19	6.16	11.32	8.83	10.57	11.33	9.95	13.70	9.44	16.00	9.04	18.36	8.75	20.73
	930	14.07	3.42	13.07	6.52	12.20	9.36	11.45	12.01	10.82	14.50	10.33	16.96	9.92	19.40	9.62	21.83
	990	15.11	3.65	14.11	6.95	13.24	9.98	12.49	12.80	11.87	15.46	11.36	18.04	10.96	20.63	10.67	23.19
	1050	16.17	3.88	15.16	7.38	14.29	10.60	13.55	13.61	12.92	16.42	12.41	19.15	12.01	21.86	11.72	24.54
	1110	17.22	4.10	16.21	7.82	15.35	11.23	14.60	14.42	13.97	17.39	13.46	20.27	13.07	23.13	12.77	25.89
	1180	18.45	4.37	17.44	8.32	16.58	11.97	15.82	15.35	15.20	18.52	14.69	21.57	14.29	24.57	13.99	27.47
	1250	19.67	4.63	18.66	8.82	17.79	12.69	17.04	16.27	16.42	19.64	15.91	22.86	15.51	26.01	15.22	29.07
	1320	20.89	4.89	19.89	9.34	19.02	13.43	18.27	17.21	17.65	20.77	17.13	24.15	16.74	27.43	16.45	30.67
	1390	22.12	5.16	21.12	9.84	20.25	14.16	19.50	18.15	18.88	21.89	18.36	25.45	17.96	28.92	17.68	32.27
	1470	23.52	5.46	22.51	10.42	21.65	14.99	20.89	19.21	20.27	23.17	19.75	26.92	19.36	30.58	19.07	34.08
	1560	25.10	5.80	24.09	11.07	23.22	15.92	22.47	20.40	21.85	24.61	21.34	28.60	20.94	32.44	20.64	36.13
	1650	26.67	6.14	25.66	11.71	24.79	16.85	24.04	21.60	23.42	26.04	22.91	30.25	22.51	34.30	22.22	38.19
	1750	28.42	6.52	27.42	12.44	26.55	17.89	25.80	22.93	25.17	27.65	24.67	32.10	24.27	36.39	23.98	40.49
	1850	30.17	6.90	29.16	13.15	28.29	18.92	27.54	24.26	26.92	29.24	26.41	33.93	26.01	38.45	25.72	42.76

Model	RPM	TYPE ASS-150 PERFORMANCE															
		1000mmAq		2000mmAq		3000mmAq		4000mmAq		5000mmAq		6000mmAq		7000mmAq		8000mmAq	
		Qs	kw	Qs	kw	Qs	kw	Qs	kw	Qs	kw	Qs	kw	Qs	kw	Qs	kw
ASS-150	780	14.90	3.69	14.14	7.05	13.44	10.14	12.81	12.99	12.24	15.62	11.71	18.06	11.29	20.33	10.86	22.41
	830	16.00	3.93	15.25	7.50	14.55	10.79	13.93	13.82	13.35	16.62	12.83	19.22	12.40	21.64	11.97	23.89
	880	17.11	4.17	16.36	7.97	15.66	11.45	15.04	14.67	14.45	17.64	13.94	20.39	13.51	22.97	13.08	25.35
	930	18.22	4.40	17.46	8.42	16.77	12.10	16.15	15.50	15.56	18.64	15.05	21.55	14.62	24.27	14.19	26.78
	990	19.55	4.69	18.79	8.95	18.10	12.88	17.48	16.49	16.89	19.85	16.38	22.94	15.95	25.84	15.52	28.51
	1050	20.88	4.97	20.12	9.50	19.43	13.66	18.81	17.49	18.22	21.04	17.71	24.33	17.28	27.40	16.85	30.24
	1110	22.21	5.25	21.45	10.04	20.76	14.44	20.14	18.49	19.55	22.24	19.04	25.72	18.61	28.97	18.18	31.94
	1180	23.76	5.59	23.00	10.67	22.31	15.36	21.69	19.66	21.10	23.65	20.59	27.36	20.16	30.81	19.73	33.98
	1250	25.31	5.92	24.55	11.31	23.86	16.27	23.24	20.83	22.65	25.06	22.14	28.99	21.71	32.61	21.28	36.00
	1320	26.86	6.26	26.10	11.94	25.41	17.18	24.78	22.00	24.20	26.47	23.68	30.62	23.26	34.33	22.83	38.02
	1390	28.41	6.59	27.65	12.58	26.96	18.09	26.33	23.16	25.75	27.87	25.23	32.21	24.81	36.26	24.38	40.04
	1470	30.18	6.96	29.42	13.30	28.73	19.13	28.10	24.49	27.52	29.47	27.00	34.06	26.57	38.35	26.15	42.34
	1560	32.17	7.38	31.41	14.12	30.72	20.30	30.09	26.00	29.51	31.28	28.99	36.15	28.56	40.71	28.14	44.93
	1650	34.16	7.81	33.40	14.94	32.71	21.46	32.08	27.51	31.50	33.06	30.98	38.25	30.55	43.07	30.12	47.53
	1750	36.37	8.28	35.61	15.84	34.92	22.77	34.29	29.18	33.71	35.07	33.19	40.57	32.76	45.68	32.33	50.41
	1850	38.58	8.76	37.82	16.75	37.12	24.07	36.49	30.85	35.92	37.09	35.39	42.90	34.97	48.30	34.54	53.28

Model	RPM	TYPE ASS-200A PERFORMANCE															
		1000mmAq		2000mmAq		3000mmAq		4000mmAq		5000mmAq		6000mmAq		7000mmAq		8000mmAq	
		Qs	kw	Qs	kw	Qs	kw	Qs	kw	Qs	kw	Qs	kw	Qs	kw	Qs	kw
ASS-200A	620	17.89	4.94	16.82	9.52	15.89	13.73	15.05	17.59	14.36	21.19	13.75	24.56	13.21	27.67	12.79	30.55
	660	19.42	5.27	18.35	10.14	17.42	14.62	16.58	18.73	15.89	22.56	15.28	26.15	14.74	29.47	14.32	32.55
	700	20.95	5.59	19.87	10.76	18.94	15.50	18.10	19.88	17.41	23.93	16.80	27.74	16.26	31.26	15.84	34.53
	740	22.47	5.91	21.40	11.37	20.47	16.39	19.63	21.02	18.94	25.30	18.33	29.33	17.79	33.06	17.37	36.52
	780	24.00	6.23	22.93	11.99	22.00	17.28	21.16	22.17	20.47	26.67	19.86	30.92	19.32	34.86	18.90	38.52
	830	25.91	6.63	24.84	12.76	23.91	18.39	23.07	23.60	22.38	28.38	21.77	32.91	21.23	37.10	20.81	41.01
	880	27.82	7.04	26.75	13.54	25.82	19.50	24.98	25.03	24.29	30.09	23.68	34.89	23.14	39.33	22.72	43.49
	930	29.73	7.44	28.66	14.31	27.73	20.61	26.89	26.46	26.20	31.81	25.59	36.88	25.05	41.58	24.63	45.98
	990	32.02	7.92	30.95	15.24	30.02	21.95	29.18	28.18	28.49	33.86	27.88	39.26	27.34	44.27	26.92	48.95
	1050	34.31	8.41	33.24	16.16	32.31	23.28	31.47	29.89	30.78	35.91	30.17	41.64	29.63	46.96	29.21	51.93
	1110	36.60	8.90	35.52	17.10	34.59	24.62	33.75	31.62	33.06	38.02	32.44	44.07	31.90	49.70	31.47	54.85
	1180	39.27	9.49	38.19	18.20	37.26	26.19	36.42	33.64	35.73	40.47	35.11	46.91	34.57	52.85	34.14	58.32
	1250	41.95	10.07	40.87	19.30	39.94	27.76	39.10	35.65	38.41	42.93	37.79	49.74	37.25	56.00	36.82	61.81
	1320	44.62	10.65	43.54	20.40	42.61	29.33	41.77	37.67	41.08	45.38	40.46	52.57	39.92	59.15	39.49	65.27
	1390	47.29	11.23	46.21	21.50	45.28	30.90	44.44	39.68	43.75	47.83	43.13	55.36	42.59	62.29	42.16	68.74
	1470	50.34	11.90	49.26	22.75	48.33	32.70	47.49	41.99	46.80	50.63	46.18	58.55	45.64	65.88	45.21	72.70

ASS PERFORMANCE TABLE

NOTE: inlet flow rate Qs=m³/min

Model	RPM	TYPE ASS-200 PERFORMANCE															
		1000mmAq		2000mmAq		3000mmAq		4000mmAq		5000mmAq		6000mmAq		7000mmAq		8000mmAq	
		Qs	kw	Qs	kw	Qs	kw	Qs	kw	Qs	kw	Qs	kw	Qs	kw	Qs	kw
ASS-200	620	23.36	6.36	21.97	12.26	20.75	17.67	19.66	22.64	18.75	27.27	17.96	31.62	17.25	35.69	16.70	39.59
	660	25.35	6.79	23.95	13.05	22.74	18.82	21.64	24.11	20.74	29.03	19.94	33.66	19.24	38.00	18.69	42.18
	700	27.33	7.20	25.92	13.85	24.70	19.96	23.61	25.59	22.71	30.80	21.91	35.71	21.21	40.31	20.66	44.75
	740	29.29	7.62	27.89	14.65	26.68	21.11	25.59	27.07	24.69	32.57	23.89	37.76	23.19	42.63	22.64	47.34
	780	31.26	8.04	29.87	15.45	28.66	22.25	27.56	28.54	26.66	34.34	25.87	39.81	25.17	44.94	24.62	49.92
	830	33.72	8.56	32.33	16.45	31.12	23.69	30.03	30.39	29.13	36.54	28.34	42.36	27.63	47.82	27.09	53.14
	880	36.18	9.09	34.79	17.45	33.58	25.13	32.49	32.23	31.59	38.75	30.80	44.92	30.09	50.70	29.55	56.37
	930	38.63	9.61	37.24	18.47	36.03	26.56	34.94	34.08	34.05	40.96	33.25	47.48	32.55	53.60	32.01	59.59
	990	41.57	10.24	40.18	19.64	38.97	28.27	37.88	36.29	36.99	43.60	36.19	50.55	35.49	57.06	34.95	63.46
	1050	44.50	10.86	43.11	20.84	41.90	30.00	40.82	38.50	39.92	46.25	39.13	53.61	38.43	60.52	37.88	67.33
	1110	47.42	11.51	46.02	22.06	44.82	31.73	43.73	40.73	42.84	48.96	42.03	56.74	41.33	64.06	40.78	71.08
	1180	50.82	12.26	49.43	23.47	48.22	33.75	47.14	43.33	46.24	52.12	45.44	60.39	44.74	68.17	44.18	75.49
	1250	54.23	13.01	52.83	24.89	51.63	35.78	50.55	45.92	49.65	55.28	48.85	64.04	48.16	72.28	47.60	79.90
	1320	57.62	13.76	56.22	26.31	55.02	37.80	53.94	48.52	53.05	58.43	52.25	67.69	51.55	76.38	50.99	84.28
	1390	61.00	14.52	59.60	27.73	58.40	39.82	57.32	51.12	56.43	61.59	55.63	71.33	54.93	80.35	54.38	88.67
1470	64.84	15.37	63.45	29.34	62.26	42.13	61.17	54.08	60.28	64.95	59.49	75.41	58.79	84.86	58.24	93.65	

Model	RPM	TYPE ASS-250 PERFORMANCE															
		1000mmAq		2000mmAq		3000mmAq		4000mmAq		5000mmAq		6000mmAq		7000mmAq		8000mmAq	
		Qs	kw	Qs	kw	Qs	kw	Qs	kw	Qs	kw	Qs	kw	Qs	kw	Qs	kw
ASS-250	620	32.49	8.21	30.56	15.92	28.86	23.01	27.35	29.49	26.08	35.58	24.98	41.09	23.99	46.18	23.23	51.11
	660	35.24	8.78	33.29	16.97	31.61	24.52	30.08	31.45	28.83	37.91	27.72	44.07	26.74	49.56	25.98	54.85
	700	37.96	9.33	36.00	18.03	34.31	26.03	32.79	33.41	31.54	40.24	30.43	46.79	29.46	52.86	28.70	58.50
	740	40.65	9.89	38.71	19.08	37.03	27.55	35.52	35.36	34.27	42.57	33.16	49.49	32.19	56.04	31.42	62.14
	780	43.36	10.45	41.43	20.14	39.75	29.05	38.23	37.32	36.98	44.90	35.88	52.20	34.91	59.10	34.15	65.77
	830	46.74	11.15	44.81	21.46	43.13	30.94	41.62	39.75	40.37	47.79	39.28	55.58	38.30	62.91	37.55	70.27
	880	50.11	11.84	48.18	22.77	46.51	32.82	45.00	42.19	43.75	50.70	42.66	58.95	41.67	66.72	40.93	74.70
	930	53.46	12.53	51.54	24.09	49.87	34.71	48.36	44.63	47.13	53.61	46.02	62.32	45.05	70.55	44.30	79.02
	990	57.49	13.36	55.57	25.66	53.90	36.96	52.39	47.56	51.16	57.08	50.05	66.37	49.08	75.13	48.34	84.19
	1050	61.50	14.18	59.58	27.24	57.91	39.23	56.41	50.49	55.17	60.57	54.08	70.41	53.11	79.71	52.35	89.37
	1110	65.49	15.07	63.55	28.86	61.90	41.53	60.39	53.46	59.16	64.22	58.04	74.62	57.08	84.47	56.32	94.56
	1180	70.13	16.10	68.21	30.77	66.54	44.21	65.05	56.91	63.81	68.46	62.71	79.53	61.74	90.01	60.97	100.60
	1250	74.78	17.12	72.85	32.66	71.20	46.90	69.71	60.37	68.47	72.72	67.36	84.43	66.41	95.56	65.64	106.66
	1320	79.40	18.15	77.47	34.57	75.82	49.60	74.33	63.83	73.10	76.98	72.00	89.33	71.04	101.12	70.26	112.73
	1390	84.00	19.18	82.07	36.48	80.42	52.29	78.93	67.28	77.70	81.23	76.60	94.25	75.64	106.68	74.88	118.79
1470	89.22	20.35	87.31	38.65	85.67	55.36	84.17	71.24	82.95	85.42	81.86	99.86	80.90	113.03	80.14	125.72	

Model	RPM	TYPE ASS-300A PERFORMANCE															
		1000mmAq		2000mmAq		3000mmAq		4000mmAq		5000mmAq		6000mmAq		7000mmAq		8000mmAq	
		Qs	kw	Qs	kw	Qs	kw	Qs	kw	Qs	kw	Qs	kw	Qs	kw	Qs	kw
ASS-300A	620	44.38	11.65	41.65	22.23	39.45	31.81	37.63	40.75	35.97	49.00	34.49	56.66	33.18	63.77	32.04	70.38
	660	48.01	12.40	45.36	23.75	43.12	33.99	41.29	43.54	39.54	52.25	38.15	60.56	36.84	68.17	35.71	75.27
	700	51.70	13.16	49.03	25.20	46.81	36.19	44.99	46.37	43.33	55.78	41.85	64.50	40.54	72.62	39.40	80.17
	740	55.34	13.91	52.70	26.63	50.50	38.30	48.67	49.05	47.01	58.98	45.53	68.21	44.22	76.87	43.09	84.83
	780	59.01	14.67	56.39	28.08	54.19	40.37	52.36	51.71	50.70	62.17	49.22	71.89	47.91	81.02	46.78	89.41
	830	63.58	15.60	60.96	29.88	58.75	42.96	56.91	55.02	55.26	66.16	53.78	76.50	52.47	86.22	51.34	95.15
	880	68.14	16.54	65.51	31.67	63.31	45.55	61.47	58.35	59.82	70.14	58.33	81.11	57.03	91.41	55.90	100.89
	930	72.66	17.49	70.05	33.48	67.85	48.14	66.01	61.66	64.36	74.13	62.87	85.72	61.57	96.51	60.44	106.63
	990	78.09	18.61	75.48	35.63	73.24	51.24	71.40	65.64	69.75	78.92	68.26	91.25	66.96	102.84	65.83	113.52
	1050	83.49	19.74	80.89	37.79	78.62	54.35	76.79	69.63	75.13	83.70	73.65	96.79	72.33	109.07	71.20	120.40
	1110	88.86	20.88	86.23	39.95	83.99	57.46	82.13	73.60	80.47	88.50	79.00	102.33	77.68	115.31	76.55	127.30
	1180	95.10	22.20	92.49	42.48	90.21	61.09	88.33	78.26	86.67	94.10	85.19	108.80	83.88	122.60	82.75	135.36
	1250	101.34	23.52	98.72	45.01	96.41	64.72	94.53	82.90	92.87	99.70	91.39	115.28	90.08	129.89	88.95	143.40
	1320	107.53	24.84	104.91	47.53	102.61	68.35	100.73	87.55	99.07	105.30	97.59	121.76	96.28	137.17	95.15	151.46
	1390	113.68	26.17	111.07	50.06	108.80	71.98	106.88	92.20	105.26	110.89	103.78	128.23	102.37	144.45	101.34	159.51
1470	120.66	27.68	118.08	52.95	115.79	76.13	113.83	97.51	112.18	117.29	110.71	135.63	109.41	152.78	108.38	168.71	

ASS PERFORMANCE TABLE

NOTE: inlet flow rate Qs=m³/min

Model	RPM	TYPE ASS-300 PERFORMANCE															
		1000mmAq		2000mmAq		3000mmAq		4000mmAq		5000mmAq		6000mmAq		7000mmAq		8000mmAq	
		Qs	kw	Qs	kw	Qs	kw	Qs	kw	Qs	kw	Qs	kw	Qs	kw	Qs	kw
ASS-300	600	72.16	16.96	69.33	30.43	67.10	43.80	64.99	57.52	63.17	70.07	61.59	84.13	60.01	95.88	58.42	109.07
	700	85.55	19.78	82.72	35.49	80.49	51.09	78.38	67.09	76.56	81.74	74.98	98.11	73.40	111.82	71.81	127.38
	800	98.94	22.60	96.11	40.56	93.88	58.38	91.77	76.69	89.95	94.00	88.37	112.10	86.79	127.76	85.20	144.79
	900	112.33	25.42	109.50	45.62	107.27	65.65	105.16	86.22	103.34	105.50	101.76	126.08	100.18	143.70	98.59	163.73
	1000	125.72	28.24	122.89	50.69	120.66	72.93	118.55	95.82	116.73	116.70	115.15	140.12	113.57	159.69	111.98	180.87
	1100	139.05	31.06	136.28	55.76	134.05	80.22	131.94	105.36	130.12	128.37	128.54	153.87	126.95	175.63	125.37	198.18
	1200	152.44	33.89	149.67	60.83	147.44	87.51	145.32	114.96	143.51	140.04	141.93	168.08	140.34	191.57	138.76	215.37
	1300	165.82	36.71	163.06	65.89	160.83	94.79	158.71	124.53	156.90	151.70	155.32	182.08	153.73	207.51	152.15	232.61
	1400	179.20	39.53	176.45	70.96	174.22	102.08	172.10	134.11	170.29	163.36	168.71	196.07	167.12	223.46	165.54	250.12

Model	RPM	TYPE ASS-350 PERFORMANCE															
		1000mmAq		2000mmAq		3000mmAq		4000mmAq		5000mmAq		6000mmAq		7000mmAq		8000mmAq	
		Qs	kw	Qs	kw	Qs	kw	Qs	kw	Qs	kw	Qs	kw	Qs	kw	Qs	kw
ASS-350	600	113.86	26.45	109.57	47.50	106.22	67.72	103.06	89.11	100.36	109.17	98.03	130.69	95.70	149.35	93.38	173.50
	700	134.90	30.88	130.61	55.39	127.26	79.11	124.10	104.02	121.40	127.51	119.07	152.57	116.74	174.40	114.41	202.64
	800	155.94	35.31	151.65	63.30	148.30	91.17	145.14	118.96	142.44	145.75	140.11	174.47	137.78	199.45	135.45	232.32
	900	176.97	39.74	172.69	73.20	169.34	102.05	166.18	133.82	163.48	164.10	161.15	196.35	158.82	224.49	156.49	260.83
	1000	198.01	44.17	193.73	79.10	190.38	114.04	187.22	148.76	184.52	182.44	182.19	218.28	179.86	249.62	177.53	289.96
	1100	218.96	48.60	214.77	87.00	211.42	125.49	208.26	163.66	205.56	200.78	203.23	239.98	200.90	274.67	198.57	318.90
	1200	240.00	53.00	235.81	94.90	232.46	136.95	229.29	178.60	226.59	219.14	224.27	262.05	221.94	299.72	219.61	347.60
	1300	261.02	57.40	256.85	102.80	253.50	148.39	250.33	193.47	247.63	237.44	245.31	283.95	242.98	324.77	240.65	376.30
	1400	282.05	61.80	277.89	110.70	274.54	159.85	271.37	208.40	268.67	255.77	266.35	305.84	264.02	349.83	261.69	405.00

Model	RPM	TYPE ASS-400 PERFORMANCE															
		1000mmAq		2000mmAq		3000mmAq		4000mmAq		5000mmAq		6000mmAq		7000mmAq		8000mmAq	
		Qs	kw	Qs	kw	Qs	kw	Qs	kw	Qs	kw	Qs	kw	Qs	kw	Qs	kw
ASS-400	600	132.68	30.77	127.69	55.24	123.78	79.50	120.09	104.41	116.95	127.18	114.23	152.71	111.52	174.03	109.13	202.14
	700	157.19	35.90	152.20	64.44	148.30	92.76	144.61	121.80	141.46	148.40	138.75	178.12	136.04	203.00	133.64	235.85
	800	181.71	41.03	176.72	73.65	172.82	106.00	169.13	139.25	165.98	169.51	163.27	203.54	160.56	231.97	158.16	269.45
	900	206.23	46.16	201.24	86.09	197.33	119.22	193.64	156.58	190.50	190.72	187.79	228.95	185.07	260.94	182.68	303.15
	1000	230.75	51.28	225.76	92.07	221.85	132.46	218.16	174.03	215.02	211.94	212.30	254.48	209.59	290.01	207.20	336.86
	1100	255.15	56.41	250.27	101.27	246.37	145.71	242.68	191.37	239.53	233.15	236.82	279.46	234.11	318.98	231.72	370.57
	1200	279.67	61.55	274.79	110.49	270.88	158.95	267.20	208.81	264.05	254.37	261.34	305.31	258.63	347.95	256.24	404.28

ASS PERFORMANCE CHART

ASS-32

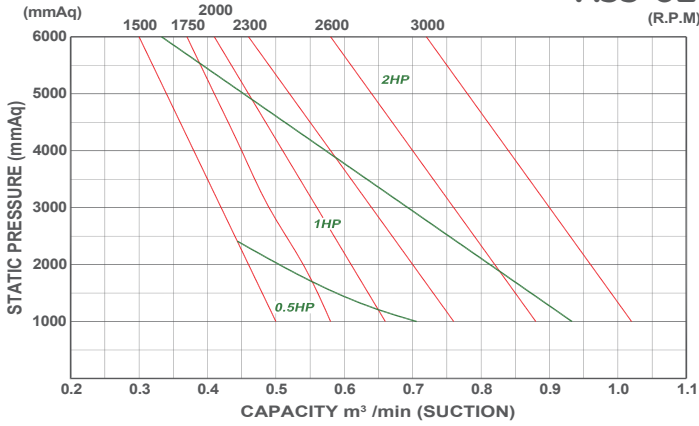

ASS-40

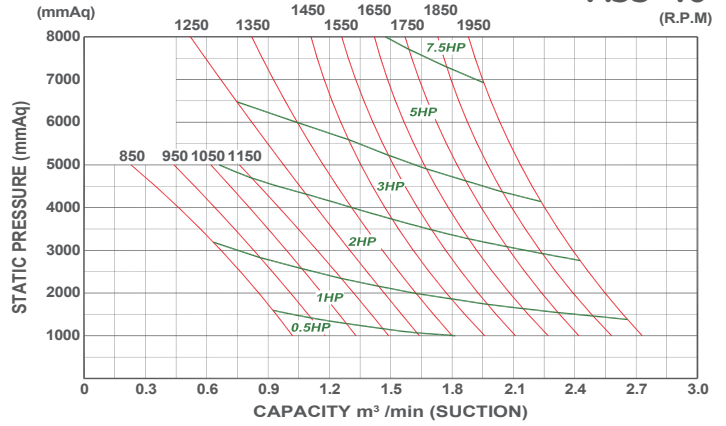

ASS-50

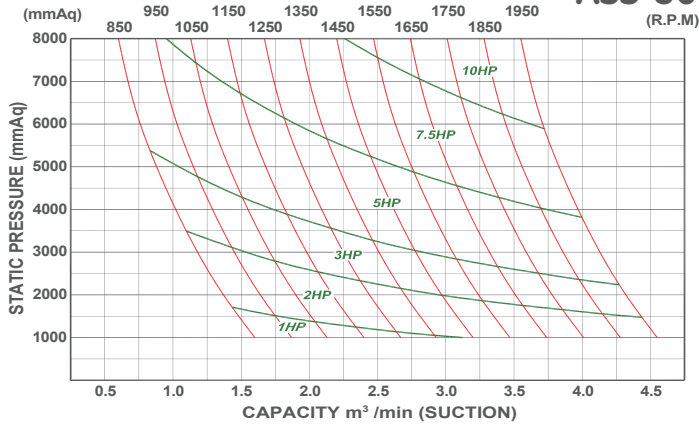

ASS-65

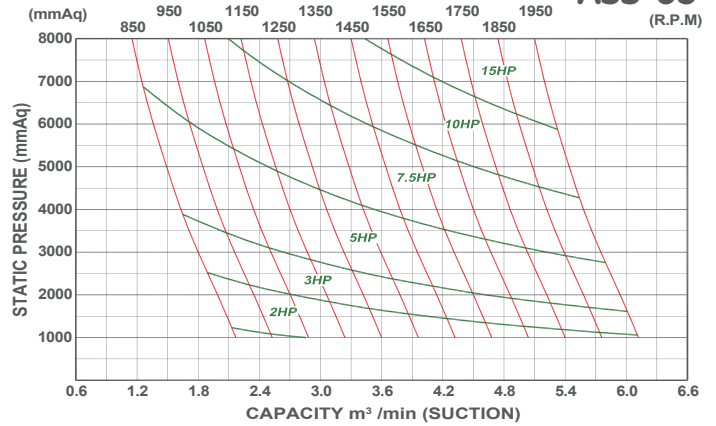

ASS-80

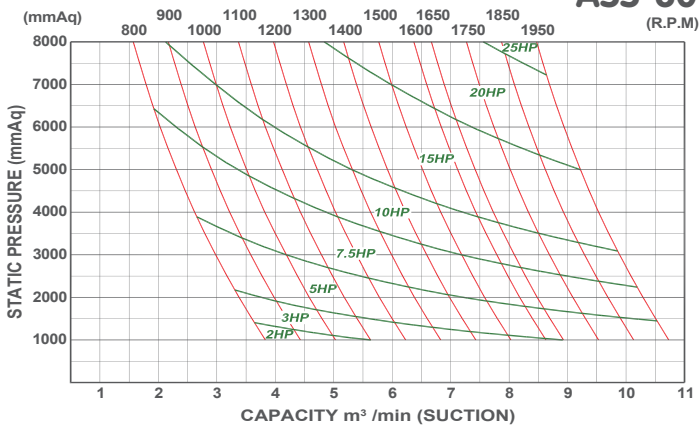

ASS-100

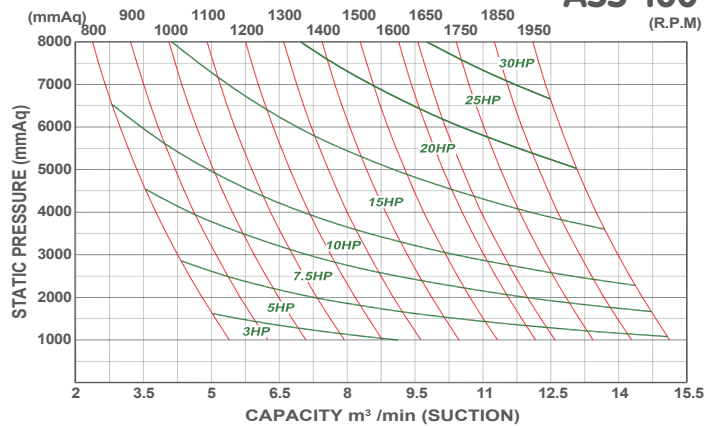

ASS-125A

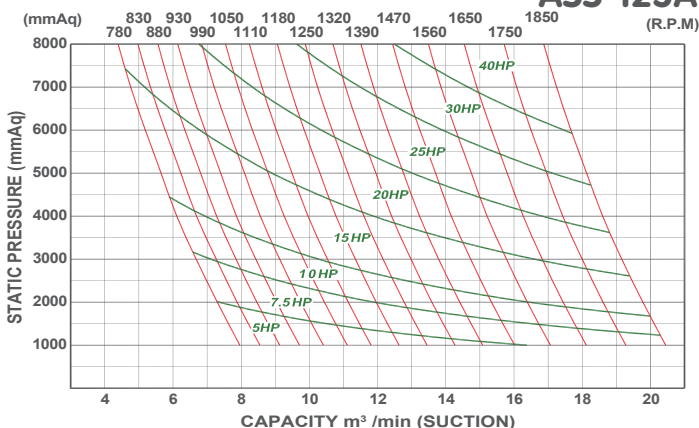

ASS-125

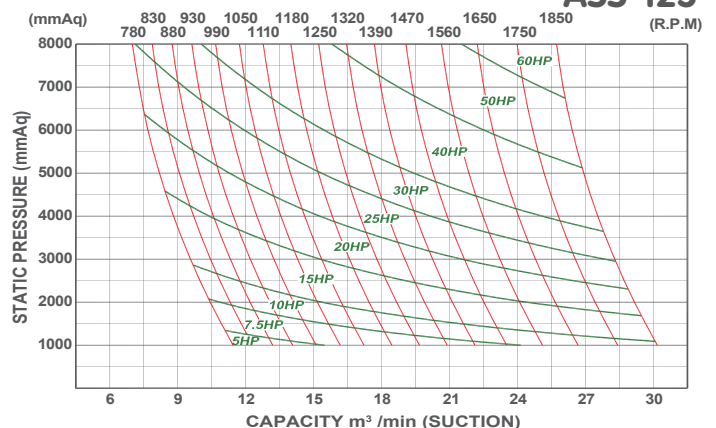

ASS PERFORMANCE CHART

ASS-150

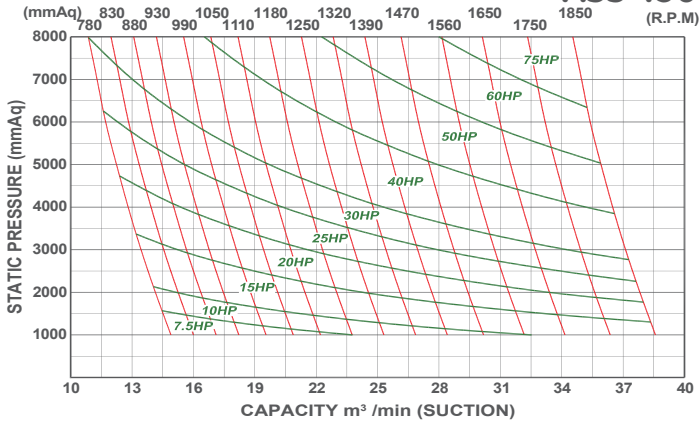

ASS-200A

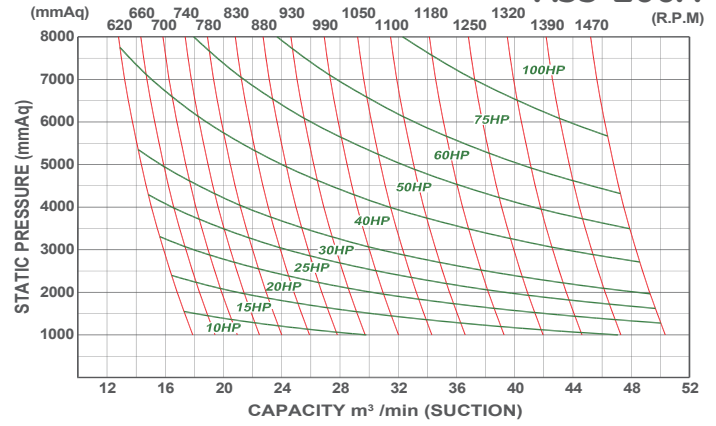

ASS-200

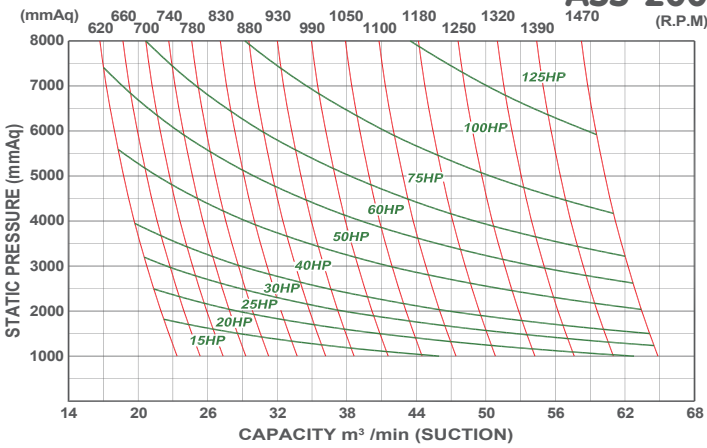

ASS-250

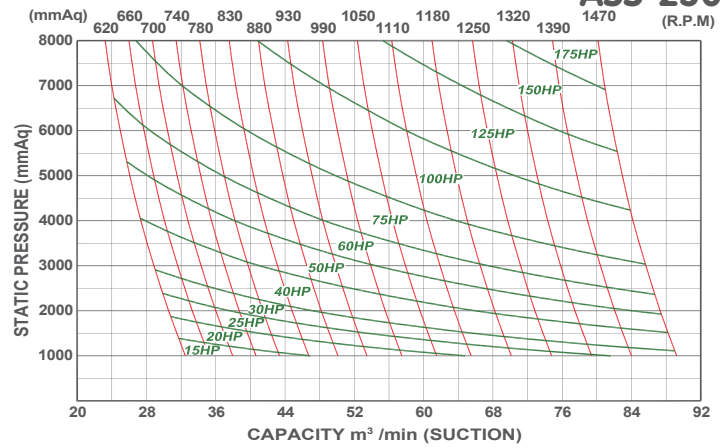

ASS-300A

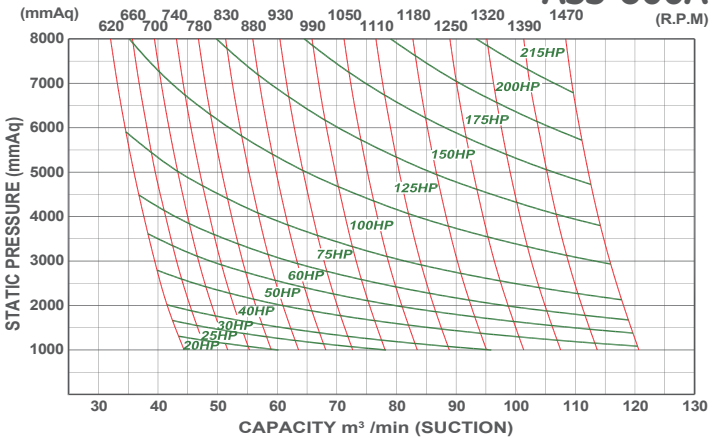

ASS-300

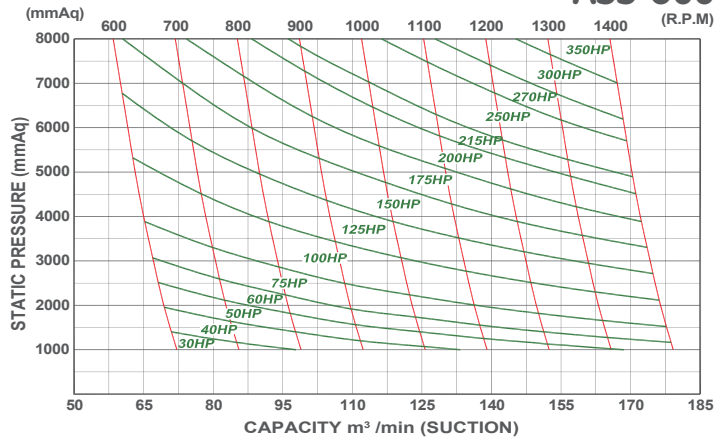

ASS-350

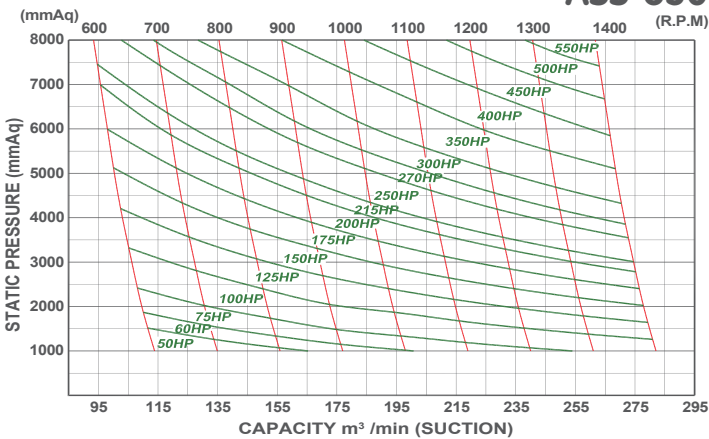

ASS-400

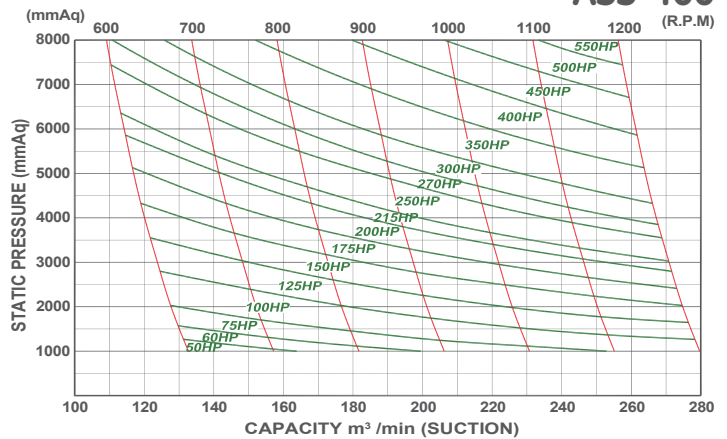

ASSV OVERALL DIMENSION

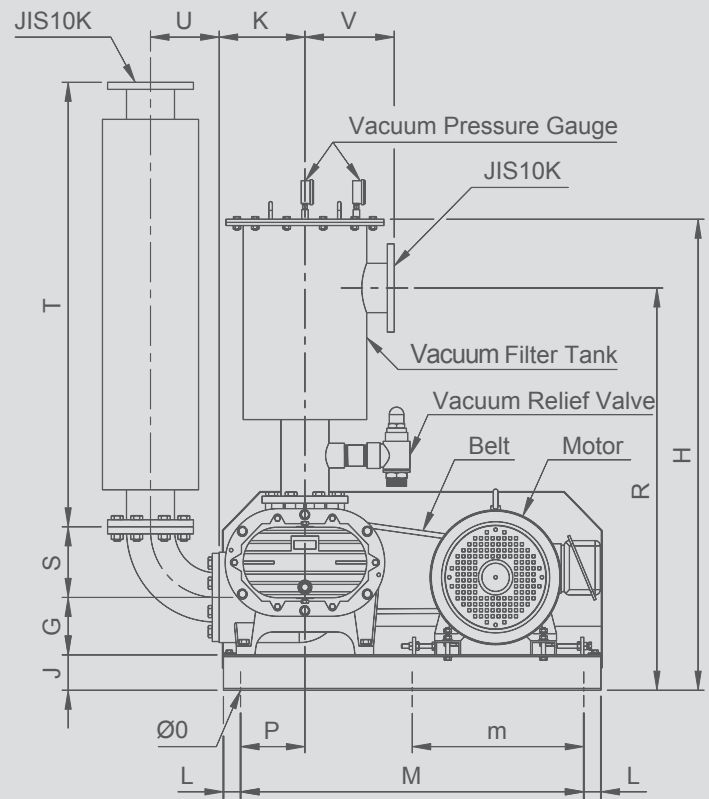
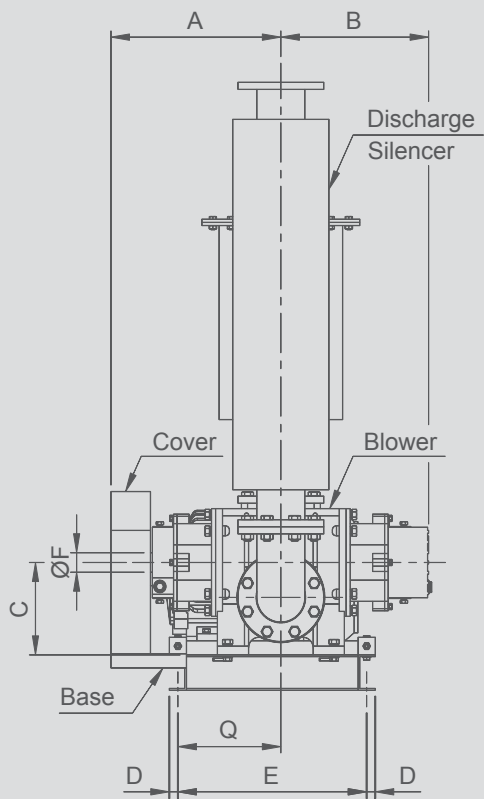

Model	A	B	C	D	E	ψF	G	H	J	K	L	M	m	ψ0	P	Q	R	U	S	T	Wt.(kg)
ASSV-40	235	202	180	20	350	28	104	988	46	140	50	500	-	14	98	255	790	82	589	121	202
ASSV-50	274	242	191	50	350	28	104	1024	75	140	37.5	795	-	12.7	208	209	826	82	589	121	202
ASSV-65	303	272	194	50	350	28	104	1027	75	152	37.5	795	-	12.7	208	238	829	105	589	105	202
ASSV-80	371	297	212	50	450	38	107	1293	75	180	37.5	945	-	12.7	228	291	1029	121	789	121	202
ASSV-100	421	347	217	50	450	38	112	1304	75	180	37.5	945	-	12.7	228	341	1040	162	789	162	202
ASSV-125A	435	371	262	25	550	48	135	1335	100	250	100	900	-	19	133	240	1140	200	1260	200	260
ASSV-125	495	431	262	25	550	48	163	1335	100	250	100	900	-	19	138	300	1140	200	1260	200	260
ASSV-150	536	486	289	25	550	48	163	1478	100	250	100	900	-	19	138	341	1243	239	1260	239	260
ASSV-200A	560	498	402	32.5	935	65	198	1830	125	360	100	1300	650	20	313	352	1525	315	1640	315	310
ASSV-200	610	548	402	32.5	935	65	198	1830	125	350	100	1300	650	20	313	403	1525	315	1640	315	310
ASSV-250	685	623	435	32.5	935	65	218	1985	125	360	100	1300	650	20	313	478	1685	391	1760	391	310
ASSV-300A	800	723	435	37.5	925	75	255	2175	150	360	235	1530	765	24	273	523	1825	465	1750	465	405
ASSV-300	780	607	550	45	1010	95	300	2480	250	510	235	2000	1000	33	325	400	2130	465	1850	465	405
ASSV-350	940	767	550	45	1110	95	300	2680	250	510	235	2000	1000	33	325	560	2280	542	2500	542	455
ASSV-400	1020	837	550	45	1110	95	300	2880	250	510	235	2000	1000	33	325	670	2380	620	2700	620	455

ASSV PERFORMANCE TABLE

NOTE: inlet flow rate Qs=m³/min

Model	RPM	TYPE ASSV-40 PERFORMANCE											
		-1000mmAq		-2000mmAq		-3000mmAq		-4000mmAq		-5000mmAq		-6000mmAq	
		Qs	kw	Qs	kw	Qs	kw	Qs	kw	Qs	kw	Qs	kw
ASSV-40	1050	1.32	0.29	1.14	0.58	0.93	0.87	0.67	1.16	-	-	-	-
	1150	1.48	0.32	1.30	0.64	1.08	0.95	0.81	1.27	-	-	-	-
	1250	1.63	0.35	1.45	0.69	1.24	1.04	1.00	1.38	-	-	-	-
	1350	1.79	0.37	1.60	0.75	1.40	1.12	1.17	1.49	-	-	-	-
	1450	1.95	0.40	1.75	0.80	1.55	1.20	1.33	1.60	1.08	2.00	0.80	2.40
	1550	2.10	0.43	1.91	0.86	1.71	1.29	1.49	1.71	1.24	2.14	0.95	2.57
	1650	2.26	0.46	2.06	0.91	1.86	1.37	1.64	1.82	1.39	2.28	1.11	2.74
	1750	2.41	0.48	2.22	0.97	2.02	1.45	1.80	1.93	1.55	2.42	1.26	2.90
	1850	2.57	0.51	2.37	1.02	2.17	1.53	1.95	2.05	1.70	2.56	1.42	3.07
	1950	2.72	0.54	2.53	1.08	2.33	1.62	2.11	2.16	1.86	2.70	1.57	3.23

Model	RPM	TYPE ASSV-50 PERFORMANCE											
		-1000mmAq		-2000mmAq		-3000mmAq		-4000mmAq		-5000mmAq		-6000mmAq	
		Qs	kw	Qs	kw	Qs	kw	Qs	kw	Qs	kw	Qs	kw
ASSV-50	1050	2.13	0.55	1.88	1.08	1.64	1.60	1.39	2.10	1.11	2.59	0.79	3.06
	1150	2.40	0.60	2.15	1.19	1.91	1.75	1.66	2.30	1.38	2.84	1.06	3.36
	1250	2.67	0.66	2.42	1.29	2.18	1.90	1.93	2.50	1.65	3.08	1.33	3.65
	1350	2.93	0.71	2.68	1.39	2.44	2.06	2.19	2.70	1.91	3.33	1.59	3.94
	1450	3.20	0.76	2.95	1.50	2.71	2.21	2.46	2.90	2.18	3.57	1.86	4.23
	1550	3.47	0.81	3.22	1.60	2.98	2.36	2.73	3.10	2.45	3.82	2.13	4.52
	1650	3.74	0.86	3.49	1.70	3.25	2.51	3.00	3.30	2.72	4.07	2.40	4.82
	1750	4.01	0.91	3.76	1.80	3.52	2.66	3.27	3.50	2.99	4.31	2.67	5.11
	1850	4.28	0.97	4.03	1.91	3.79	2.82	3.54	3.70	3.26	4.56	2.94	5.40
	1950	4.55	1.02	4.30	2.01	4.06	2.97	3.81	3.90	3.53	4.80	3.21	5.69

Model	RPM	TYPE ASSV-65 PERFORMANCE											
		-1000mmAq		-2000mmAq		-3000mmAq		-4000mmAq		-5000mmAq		-6000mmAq	
		Qs	kw	Qs	kw	Qs	kw	Qs	kw	Qs	kw	Qs	kw
ASSV-65	1050	2.87	0.75	2.67	1.48	2.42	2.17	2.14	2.84	1.83	3.47	1.46	4.09
	1150	3.23	0.83	3.03	1.62	2.78	2.37	2.50	3.10	2.19	3.80	1.82	4.48
	1250	3.59	0.90	3.39	1.77	3.14	2.58	2.86	3.38	2.55	4.13	2.18	4.87
	1350	3.95	0.97	3.75	1.91	3.50	2.79	3.22	3.65	2.91	4.46	2.54	5.26
	1450	4.31	1.05	4.11	2.04	3.86	3.00	3.58	3.92	3.27	4.79	2.90	5.65
	1550	4.67	1.12	4.47	2.19	4.22	3.21	3.94	4.19	3.63	5.12	3.26	6.04
	1650	5.03	1.19	4.83	2.33	4.58	3.41	4.30	4.46	3.99	5.46	3.62	6.43
	1750	5.39	1.26	5.19	2.47	4.94	3.62	4.66	4.73	4.35	5.79	3.98	6.82
	1850	5.75	1.34	5.55	2.61	5.30	3.83	5.02	5.00	4.71	6.12	4.34	7.21
	1950	6.11	1.41	5.91	2.76	5.66	4.04	5.38	5.27	5.07	6.45	4.70	7.60

Model	RPM	TYPE ASSV-80 PERFORMANCE											
		-1000mmAq		-2000mmAq		-3000mmAq		-4000mmAq		-5000mmAq		-6000mmAq	
		Qs	kw	Qs	kw	Qs	kw	Qs	kw	Qs	kw	Qs	kw
ASSV-80	1000	5.01	1.36	4.53	2.60	4.01	3.73	3.40	4.77	2.73	5.74	1.96	6.63
	1100	5.61	1.49	5.13	2.85	4.61	4.11	4.01	5.25	3.34	6.32	2.56	7.30
	1200	6.21	1.63	5.73	3.11	5.21	4.48	4.61	5.73	3.94	6.89	3.16	7.96
	1300	6.81	1.76	6.33	3.37	5.81	4.85	5.21	6.21	4.54	7.47	3.76	8.62
	1400	7.41	1.90	6.93	3.63	6.41	5.23	5.81	6.69	5.14	8.04	4.37	9.29
	1500	8.01	2.03	7.53	3.89	7.01	5.60	6.41	7.17	5.74	8.61	4.97	9.95
	1600	8.61	2.17	8.13	4.15	7.61	5.97	7.01	7.64	6.34	9.19	5.57	10.61
	1650	8.91	2.24	8.43	4.28	7.91	6.16	7.31	7.88	6.64	9.47	5.87	10.95
	1750	9.51	2.38	9.04	4.54	8.51	6.53	7.91	8.36	7.24	10.04	6.47	11.61
	1850	10.11	2.52	9.64	4.80	9.11	6.90	8.51	8.83	7.84	10.62	7.07	12.28
	1950	10.71	2.65	10.24	5.06	9.71	7.28	9.11	9.31	8.44	11.19	7.67	12.94

ASSV PERFORMANCE TABLE

NOTE: inlet flow rate Qs=m³/min

Model	RPM	TYPE ASSV-100 PERFORMANCE											
		-1000mmAq		-2000mmAq		-3000mmAq		-4000mmAq		-5000mmAq		-6000mmAq	
		Qs	kw	Qs	kw	Qs	kw	Qs	kw	Qs	kw	Qs	kw
ASSV-100	1000	7.08	1.78	6.45	3.42	5.74	4.90	4.94	6.30	4.04	7.56	3.02	8.79
	1100	7.93	1.97	7.29	3.76	6.59	5.40	5.78	6.93	4.89	8.35	3.86	9.70
	1200	8.77	2.16	8.14	4.10	7.43	5.91	6.63	7.56	5.73	9.13	4.71	10.61
	1300	9.62	2.35	8.98	4.44	8.28	6.41	7.47	8.19	6.58	9.92	5.55	11.53
	1400	10.46	2.52	9.83	4.77	9.12	6.87	8.32	8.81	7.42	10.66	6.40	12.40
	1500	11.31	2.69	10.67	5.10	9.97	7.34	9.16	9.44	8.27	11.41	7.24	13.27
	1600	12.15	2.86	11.52	5.44	10.81	7.81	10.01	10.06	9.11	12.16	8.09	14.15
	1650	12.58	2.95	11.94	5.61	11.24	8.05	10.43	10.37	9.54	12.55	8.51	14.57
	1750	13.42	3.13	12.79	5.96	12.08	8.55	11.28	11.01	10.38	13.32	9.36	15.41
	1850	14.27	3.30	13.63	6.30	12.93	9.04	12.12	11.65	11.23	14.08	10.20	16.24
1950	15.11	3.48	14.48	6.65	13.77	9.53	12.97	12.28	12.07	14.85	11.05	17.08	

Model	RPM	TYPE ASSV-125A PERFORMANCE											
		-1000mmAq		-2000mmAq		-3000mmAq		-4000mmAq		-5000mmAq		-6000mmAq	
		Qs	kw	Qs	kw	Qs	kw	Qs	kw	Qs	kw	Qs	kw
ASSV-125A	990	10.39	2.46	9.66	4.72	8.82	6.79	7.84	8.69	6.78	10.46	5.52	12.08
	1050	11.09	2.61	10.36	5.00	9.52	7.20	8.54	9.22	7.47	11.09	6.21	12.82
	1110	11.79	2.76	11.06	5.29	10.22	7.62	9.24	9.75	8.17	11.72	6.91	13.55
	1180	12.61	2.93	11.88	5.62	11.04	8.10	10.06	10.37	8.99	12.47	7.73	14.41
	1250	13.43	3.10	12.70	5.96	11.85	8.58	10.88	10.98	9.81	13.21	8.55	15.26
	1320	14.25	3.28	13.51	6.29	12.67	9.06	11.69	11.60	10.63	13.95	9.36	16.12
	1390	15.06	3.45	14.33	6.63	13.48	9.54	12.51	12.22	11.44	14.69	10.18	16.98
	1470	16.00	3.65	15.26	7.01	14.42	10.09	13.44	12.92	12.38	15.54	11.12	17.96
	1560	17.05	3.88	16.31	7.44	15.47	10.71	14.49	13.71	13.43	16.49	12.17	19.06
	1650	18.10	4.11	17.36	7.87	16.52	11.33	15.55	14.51	14.48	17.44	13.22	20.16
	1750	19.26	4.36	18.53	8.35	17.69	12.02	16.71	15.39	15.64	18.50	14.38	21.38
	1850	20.43	4.61	19.70	8.82	18.85	12.70	17.88	16.27	16.81	19.56	15.55	22.60

Model	RPM	TYPE ASSV-125 PERFORMANCE											
		-1000mmAq		-2000mmAq		-3000mmAq		-4000mmAq		-5000mmAq		-6000mmAq	
		Qs	kw	Qs	kw	Qs	kw	Qs	kw	Qs	kw	Qs	kw
ASSV-125	990	15.07	3.65	14.00	6.95	12.87	9.98	11.66	12.80	10.37	15.46	8.97	18.04
	1050	16.13	3.88	15.05	7.38	13.92	10.60	12.72	13.61	11.42	16.42	10.02	19.15
	1110	17.18	4.10	16.10	7.82	14.98	11.23	13.77	14.42	12.47	17.39	11.07	20.27
	1180	18.41	4.37	17.33	8.32	16.21	11.97	14.99	15.35	13.70	18.52	12.30	21.57
	1250	19.63	4.63	18.55	8.82	17.42	12.69	16.21	16.27	14.92	19.64	13.52	22.86
	1320	20.85	4.89	19.78	9.34	18.65	13.43	17.44	17.21	16.15	20.77	14.74	24.15
	1390	22.08	5.16	21.01	9.84	19.88	14.16	18.67	18.15	17.38	21.89	15.97	25.45
	1470	23.48	5.46	22.40	10.42	21.28	14.99	20.06	19.21	18.77	23.17	17.36	26.92
	1560	25.06	5.80	23.98	11.07	22.85	15.92	21.64	20.40	20.35	24.61	18.95	28.60
	1650	26.63	6.14	25.55	11.71	24.42	16.85	23.21	21.60	21.92	26.04	20.52	30.25
	1750	28.38	6.52	27.31	12.44	26.18	17.89	24.97	22.93	23.67	27.65	22.28	32.10
	1850	30.13	6.90	29.05	13.15	27.92	18.92	26.71	24.26	25.42	29.24	24.02	33.93

ASSV PERFORMANCE TABLE

NOTE: inlet flow rate Qs=m³/min

Model	RPM	TYPE ASSV-150 PERFORMANCE											
		-1000mmAq		-2000mmAq		-3000mmAq		-4000mmAq		-5000mmAq		-6000mmAq	
		Qs	kw	Qs	kw	Qs	kw	Qs	kw	Qs	kw	Qs	kw
ASSV-150	990	19.53	4.69	18.70	8.95	17.76	12.88	16.70	16.49	15.47	19.85	14.11	22.94
	1050	20.86	4.97	20.03	9.50	19.09	13.66	18.03	17.49	16.80	21.04	15.44	24.33
	1110	22.19	5.25	21.36	10.04	20.42	14.44	19.36	18.49	18.13	22.24	16.77	25.72
	1180	23.74	5.59	22.91	10.67	21.97	15.36	20.91	19.66	19.68	23.65	18.32	27.36
	1250	25.29	5.92	24.46	11.31	23.52	16.27	22.46	20.83	21.23	25.06	19.87	28.99
	1320	26.84	6.26	26.01	11.94	25.07	17.18	24.00	22.00	22.78	26.47	21.41	30.62
	1390	28.39	6.59	27.56	12.58	26.62	18.09	25.55	23.16	24.33	27.87	22.96	32.21
	1470	30.16	6.96	29.33	13.30	28.39	19.13	27.32	24.49	26.10	29.47	24.73	34.06
	1560	32.15	7.38	31.32	14.12	30.38	20.30	29.31	26.00	28.09	31.28	26.72	36.15
	1650	34.14	7.81	33.31	14.94	32.37	21.46	31.30	27.51	30.08	33.06	28.71	38.25
	1750	36.35	8.28	35.52	15.84	34.58	22.77	33.51	29.18	32.29	35.07	30.92	40.57
1850	38.56	8.76	37.73	16.75	36.78	24.07	35.71	30.85	34.50	37.09	33.12	42.90	

Model	RPM	TYPE ASSV-200A PERFORMANCE											
		-1000mmAq		-2000mmAq		-3000mmAq		-4000mmAq		-5000mmAq		-6000mmAq	
		Qs	kw	Qs	kw	Qs	kw	Qs	kw	Qs	kw	Qs	kw
ASSV-200A	990	32.00	7.92	30.86	15.24	29.65	21.95	28.31	28.18	26.89	33.86	25.31	39.26
	1050	34.29	8.41	33.15	16.16	31.94	23.28	30.60	29.89	29.18	35.91	27.60	41.64
	1110	36.58	8.90	35.43	17.10	34.22	24.62	32.88	31.62	31.46	38.02	29.87	44.07
	1180	39.25	9.49	38.10	18.20	36.89	26.19	35.55	33.64	34.13	40.47	32.54	46.91
	1250	41.93	10.07	40.78	19.30	39.57	27.76	38.23	35.65	36.81	42.93	35.22	49.74
	1320	44.60	10.65	43.45	20.40	42.24	29.33	40.90	37.67	39.48	45.38	37.89	52.57
	1390	47.27	11.23	46.12	21.50	44.91	30.90	43.57	39.68	42.15	47.83	40.56	55.36
	1470	50.32	11.90	49.17	22.75	47.96	32.70	46.62	41.99	45.20	50.63	43.61	58.55

Model	RPM	TYPE ASSV-200 PERFORMANCE											
		-1000mmAq		-2000mmAq		-3000mmAq		-4000mmAq		-5000mmAq		-6000mmAq	
		Qs	kw	Qs	kw	Qs	kw	Qs	kw	Qs	kw	Qs	kw
ASSV-200	990	41.57	10.24	40.07	19.64	38.48	28.27	36.73	36.29	34.89	43.60	32.84	50.55
	1050	44.50	10.86	43.00	20.84	41.41	30.00	39.67	38.50	37.82	46.25	35.78	53.61
	1110	47.42	11.51	45.91	22.06	44.33	31.73	42.58	40.73	40.74	48.96	38.68	56.74
	1180	50.82	12.26	49.32	23.47	47.73	33.75	45.99	43.33	44.14	52.12	42.09	60.39
	1250	54.23	13.01	52.72	24.89	51.14	35.78	49.40	45.92	47.55	55.28	45.50	64.04
	1320	57.62	13.76	56.11	26.31	54.53	37.80	52.79	48.52	50.95	58.43	48.90	67.69
	1390	61.00	14.52	59.49	27.73	57.91	39.82	56.17	51.12	54.33	61.59	52.28	71.33
	1470	64.84	15.37	63.34	29.34	61.77	42.13	60.02	54.08	58.18	64.95	56.14	75.41

Model	RPM	TYPE ASSV-250 PERFORMANCE											
		-1000mmAq		-2000mmAq		-3000mmAq		-4000mmAq		-5000mmAq		-6000mmAq	
		Qs	kw	Qs	kw	Qs	kw	Qs	kw	Qs	kw	Qs	kw
ASSV-250	990	57.43	13.36	55.39	25.66	53.22	36.96	50.82	47.56	48.30	57.08	45.49	66.37
	1050	61.44	14.18	59.40	27.24	57.23	39.23	54.84	50.49	52.31	60.57	49.52	70.41
	1110	65.43	15.07	63.37	28.86	61.22	41.53	58.82	53.46	56.30	64.22	53.48	74.62
	1180	70.07	16.10	68.03	30.77	65.86	44.21	63.48	56.91	60.95	68.46	58.15	79.53
	1250	74.72	17.12	72.67	32.66	70.52	46.90	68.14	60.37	65.61	72.72	62.80	84.43
	1320	79.34	18.15	77.29	34.57	75.14	49.60	72.76	63.83	70.24	76.98	67.44	89.33
	1390	83.94	19.18	81.89	36.48	79.74	52.29	77.36	67.28	74.84	81.23	72.04	94.25
	1470	89.16	20.35	87.13	38.65	84.99	55.36	82.60	71.24	80.09	85.42	77.30	99.86

ASSV PERFORMANCE TABLE

NOTE: inlet flow rate Qs=m³/min

Model	RPM	TYPE ASSV-300A PERFORMANCE											
		-1000mmAq		-2000mmAq		-3000mmAq		-4000mmAq		-5000mmAq		-6000mmAq	
		Qs	kw	Qs	kw	Qs	kw	Qs	kw	Qs	kw	Qs	kw
ASSV-300A	990	77.99	18.61	75.23	35.63	72.30	51.24	69.22	65.64	65.77	78.92	61.91	91.25
	1050	83.39	19.74	80.64	37.79	77.68	54.35	74.61	69.63	71.15	83.70	67.30	96.79
	1110	88.76	20.88	85.98	39.95	83.05	57.46	79.95	73.60	76.49	88.50	72.65	102.33
	1180	95.00	22.20	92.24	42.48	89.27	61.09	86.15	78.26	82.69	94.10	78.84	108.80
	1250	101.24	23.52	98.47	45.01	95.47	64.72	92.35	82.90	88.89	99.70	85.04	115.28
	1320	107.43	24.84	104.66	47.53	101.67	68.35	98.55	87.55	95.09	105.30	91.24	121.76
	1390	113.58	26.17	110.82	50.06	107.86	71.98	104.70	92.20	101.28	110.89	97.43	128.23
1470	120.56	27.68	117.83	52.95	114.85	76.13	111.65	97.51	108.20	117.29	104.36	135.63	

Model	RPM	TYPE ASSV-300 PERFORMANCE											
		-1000mmAq		-2000mmAq		-3000mmAq		-4000mmAq		-5000mmAq		-6000mmAq	
		Qs	kw	Qs	kw	Qs	kw	Qs	kw	Qs	kw	Qs	kw
ASSV-300	800	98.94	22.60	95.93	40.56	92.85	58.38	89.21	76.69	85.17	94.00	80.67	112.10
	900	112.33	25.42	109.32	45.62	106.24	65.65	102.60	86.22	98.56	105.50	94.06	126.08
	1000	125.72	28.24	122.71	50.69	119.63	72.93	115.99	95.82	111.95	116.70	107.45	140.12
	1100	139.05	31.06	136.10	55.76	133.02	80.22	129.38	105.36	125.34	128.37	120.84	153.87
	1200	152.44	33.89	149.49	60.83	146.41	87.51	142.76	114.96	138.73	140.04	134.23	168.08
	1300	165.82	36.71	162.88	65.89	159.80	94.79	156.15	124.53	152.12	151.70	147.62	182.08
	1400	179.20	39.53	176.27	70.96	173.19	102.08	169.54	134.11	165.51	163.36	161.01	196.07

Model	RPM	TYPE ASSV-350 PERFORMANCE											
		-1000mmAq		-2000mmAq		-3000mmAq		-4000mmAq		-5000mmAq		-6000mmAq	
		Qs	kw	Qs	kw	Qs	kw	Qs	kw	Qs	kw	Qs	kw
ASSV-350	800	155.92	35.31	151.40	63.30	146.82	91.17	141.42	118.96	135.46	145.75	128.84	174.47
	900	176.95	39.74	172.44	73.20	167.86	102.05	162.46	133.82	156.50	164.10	149.88	196.35
	1000	197.99	44.17	193.48	79.10	188.90	114.04	183.50	148.76	177.54	182.44	170.92	218.28
	1100	218.94	48.60	214.52	87.00	209.94	125.49	204.54	163.66	198.58	200.78	191.96	239.98
	1200	239.98	53.00	235.56	94.90	230.98	136.95	225.57	178.60	219.61	219.14	213.00	262.05
	1300	261.00	57.40	256.60	102.80	252.02	148.39	246.61	193.47	240.65	237.44	234.04	283.95
	1400	282.03	61.80	277.64	110.70	273.06	159.85	267.65	208.40	261.69	255.77	255.08	305.84

Model	RPM	TYPE ASSV-400 PERFORMANCE											
		-1000mmAq		-2000mmAq		-3000mmAq		-4000mmAq		-5000mmAq		-6000mmAq	
		Qs	kw	Qs	kw	Qs	kw	Qs	kw	Qs	kw	Qs	kw
ASSV-400	800	181.61	41.03	176.34	73.65	171.01	106.00	164.73	139.25	157.82	169.51	150.17	203.54
	900	206.13	46.16	200.86	86.09	195.52	119.22	189.24	156.58	182.34	190.72	174.69	228.95
	1000	230.65	51.28	225.38	92.07	220.04	132.46	213.76	174.03	206.86	211.94	199.20	254.48
	1100	255.05	56.41	249.89	101.27	244.56	145.71	238.28	191.37	231.37	233.15	223.72	279.46
	1200	279.57	61.55	274.41	110.49	269.07	158.95	262.80	208.81	255.89	254.37	248.24	305.31

ASSV PERFORMANCE CHART

ASSV-40

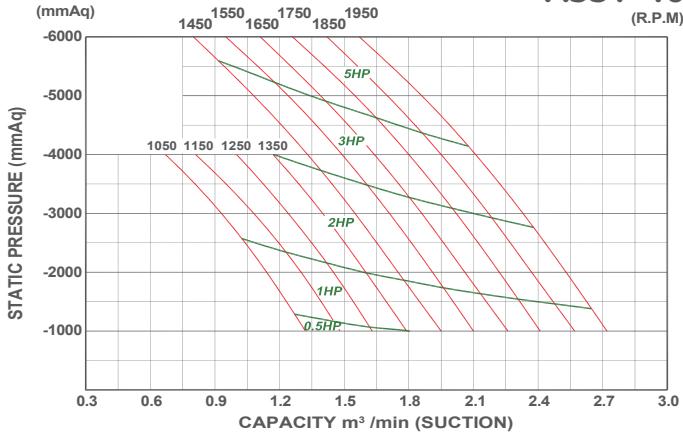

ASSV-50

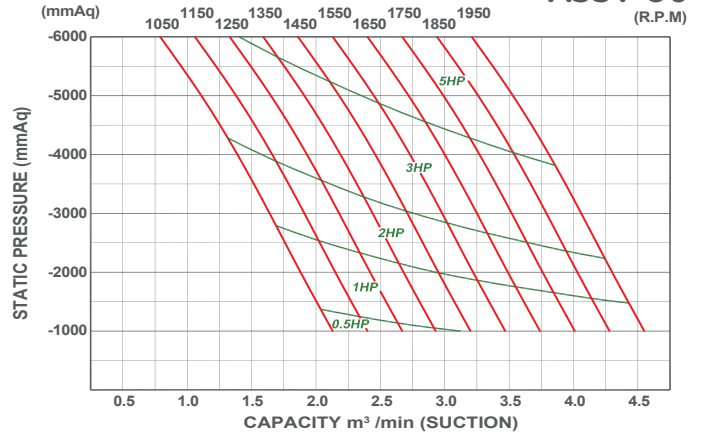

ASSV-65

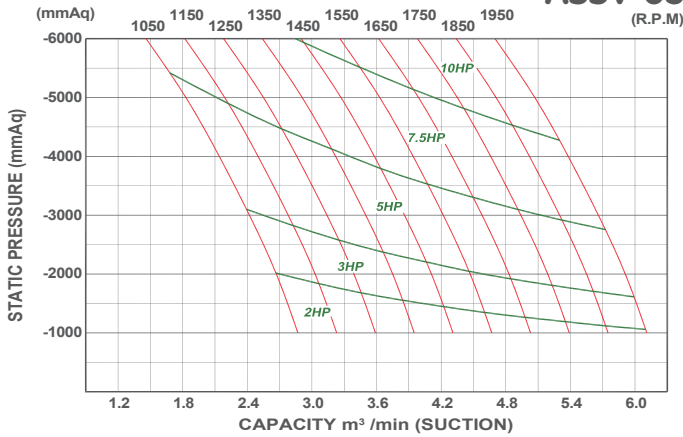

ASSV-80

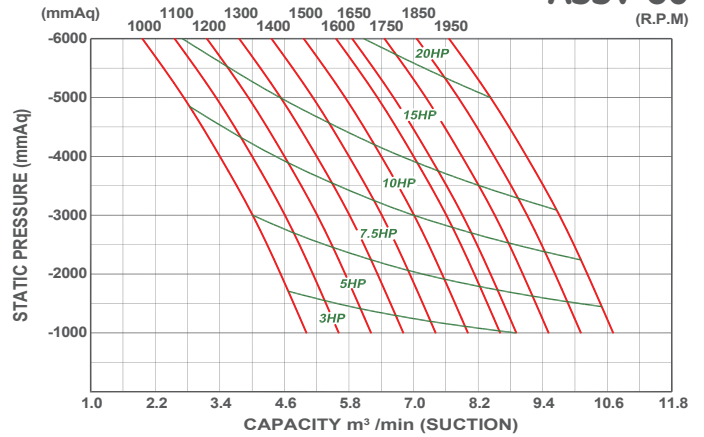

ASSV-100

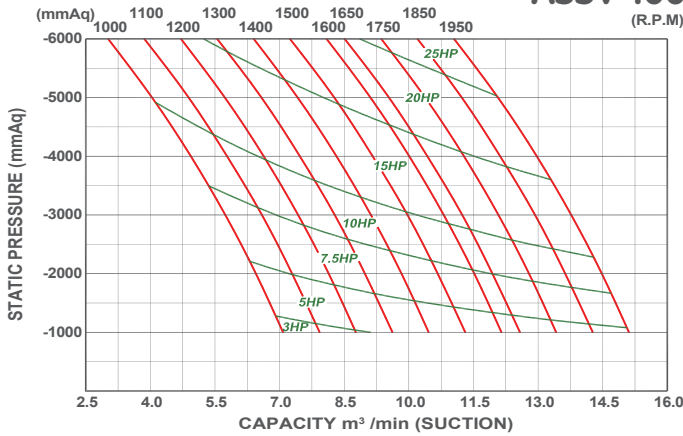

ASSV-125A

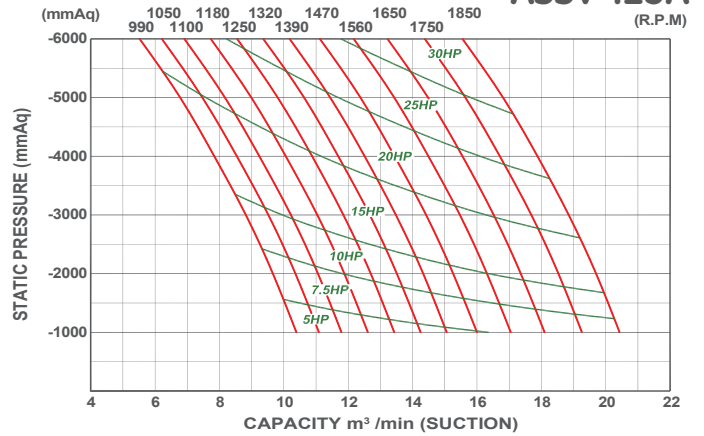

ASSV-125

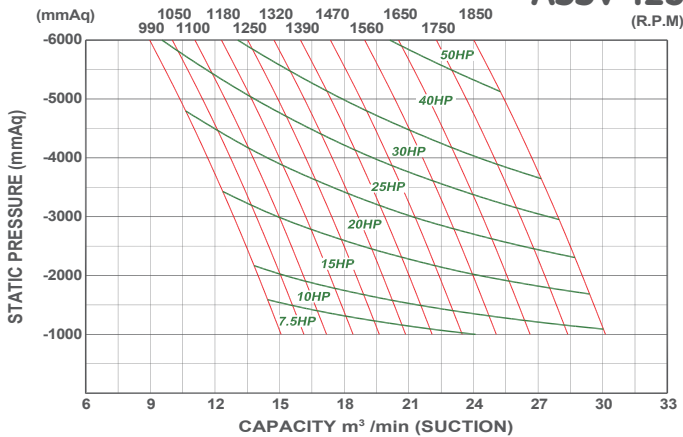

ASSV-150

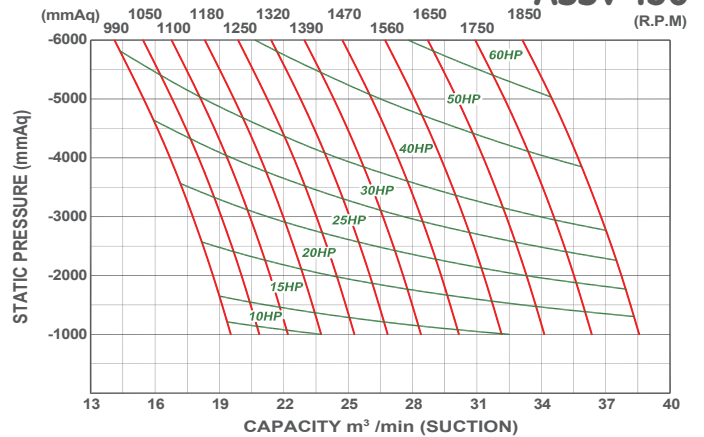

ASSV PERFORMANCE CHART

ASSV-200A

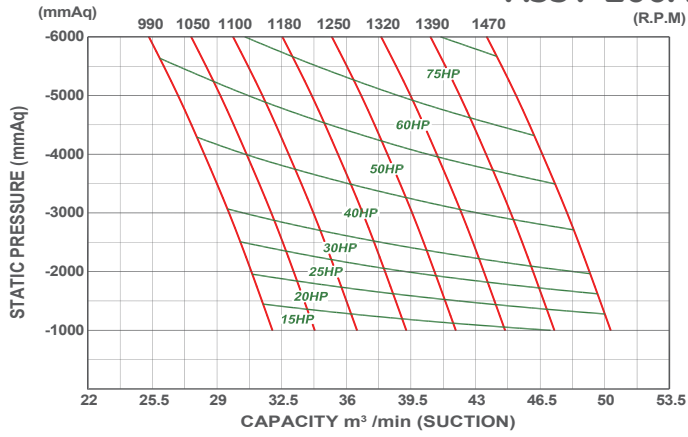

ASSV-200

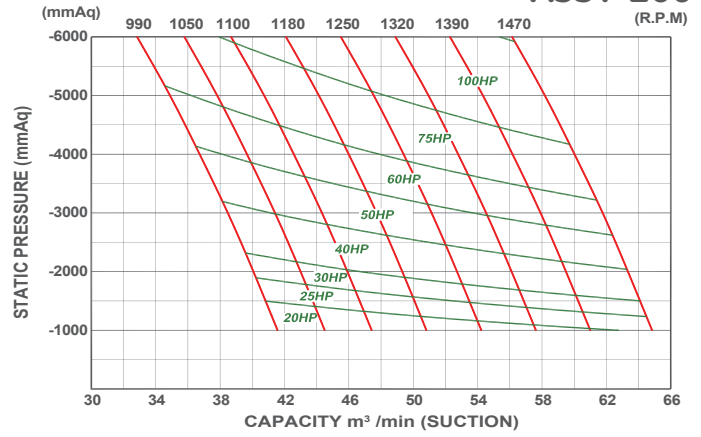

ASSV-250

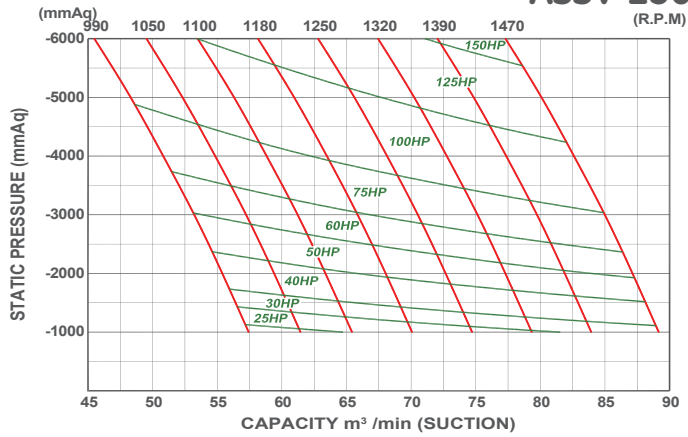

ASSV-300A

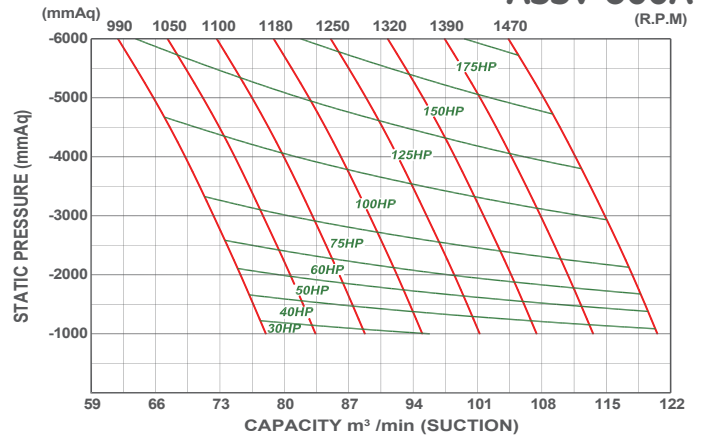

ASSV-300

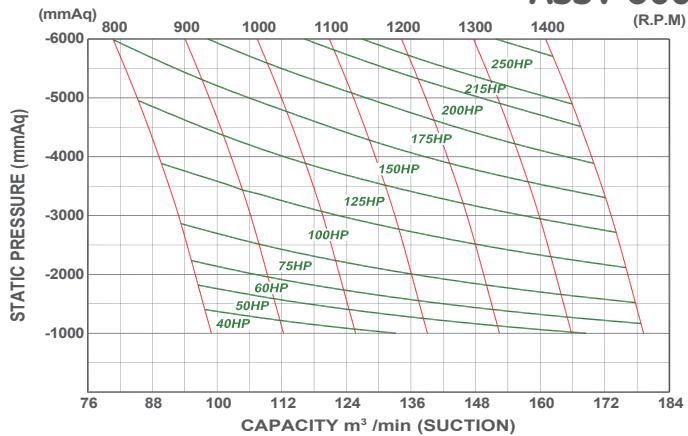

ASSV-350

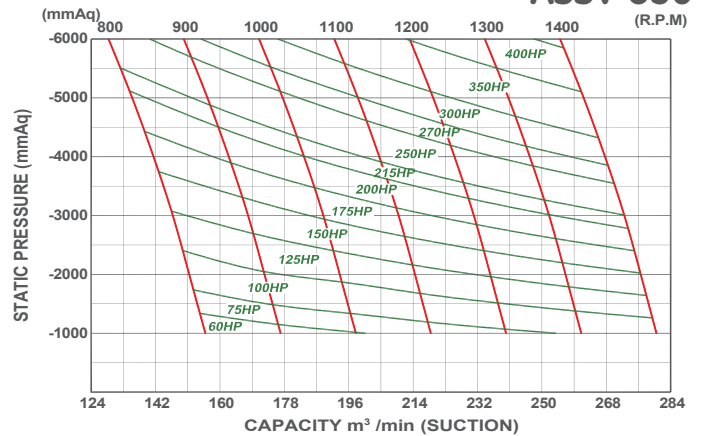

ASSV-400

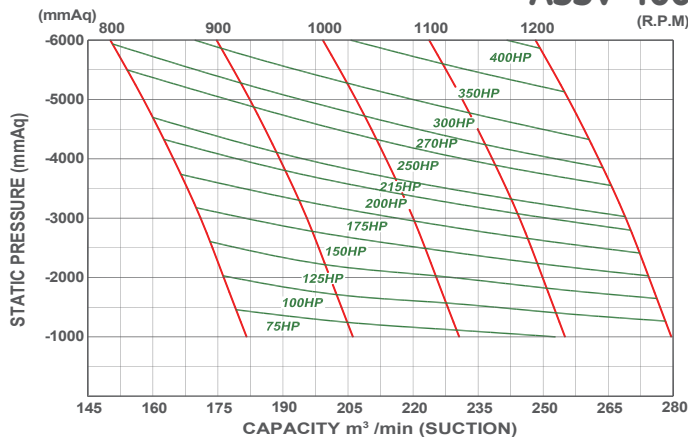

ASSW PERFORMANCE TABLE

NOTE: inlet flow rate Qs=m³/min

Model	Bore Inch (mm)	RPM	8000mmAq		9000mmAq		10000mmAq		Cooling Water Volume (L/min)
			Qs	kw	Qs	kw	Qs	kw	
ASSW-40	1.5(40)	1450	0.94	3.21	0.81	3.61	0.67	4.01	4
		1550	1.07	3.43	0.94	3.86	0.81	4.28	
		1650	1.21	3.65	1.07	4.10	0.94	4.56	
		1750	1.34	3.87	1.21	4.35	1.07	4.84	
		1850	1.47	4.09	1.34	4.60	1.20	5.11	
		1950	1.60	4.31	1.47	4.85	1.33	5.39	
ASSW-50	2(50)	1450	1.84	5.34	1.73	6.01	1.66	6.68	4
		1550	2.10	5.71	1.99	6.43	1.92	7.14	
		1650	2.36	6.08	2.25	6.84	2.18	7.60	
		1750	2.62	6.45	2.51	7.26	2.44	8.06	
		1850	2.87	6.82	2.77	7.67	2.70	8.52	
		1950	3.13	7.19	3.03	8.09	2.95	8.98	
ASSW-65	2 1/2(65)	1350	2.82	6.47	2.69	7.28	2.58	8.09	6
		1450	3.16	6.95	3.03	7.82	2.92	8.68	
		1550	3.50	7.43	3.37	8.35	3.26	9.28	
		1650	3.83	7.91	3.71	8.89	3.59	9.88	
ASSW-80	3(80)	1300	4.13	11.06	3.78	12.44	3.44	13.82	8
		1400	4.73	11.91	4.38	13.39	4.04	14.88	
		1500	5.33	12.76	4.98	14.35	4.64	15.95	
		1600	5.93	13.61	5.57	15.31	5.24	17.01	
		1650	6.23	14.03	5.87	15.79	5.54	17.54	
		1750	6.82	14.88	6.47	16.74	6.13	18.60	
		1850	7.42	15.73	7.07	17.70	6.73	19.67	
		1950	8.02	16.58	7.67	18.66	7.33	20.73	
ASSW-100	4(100)	1200	6.69	14.29	6.43	16.07	6.20	17.86	10
		1300	7.53	15.48	7.27	17.41	7.04	19.35	
		1400	8.37	16.67	8.11	18.75	7.88	20.84	
		1500	9.21	17.86	8.95	20.09	8.72	22.32	
ASSW-125A	5(125)	1180	9.15	20.59	8.52	23.16	7.78	25.73	12
		1250	10.01	21.81	9.38	24.53	8.64	27.26	
		1320	10.87	23.03	10.24	25.91	9.50	28.78	
		1390	11.73	24.25	11.10	27.28	10.36	30.31	
		1470	12.71	25.64	12.08	28.85	11.34	32.06	
		1560	13.82	27.21	13.19	30.62	12.45	34.02	
		1650	14.92	28.78	14.29	32.38	13.56	35.98	
		1750	16.15	30.53	15.52	34.35	14.78	38.16	
ASSW-125	5(125)	1180	14.35	30.09	13.55	33.85	12.61	37.61	12
		1250	15.61	31.87	14.80	35.86	13.86	39.84	
		1320	16.87	33.66	16.06	37.86	15.12	42.07	
		1390	18.12	35.44	17.32	39.87	16.38	44.30	
		1470	19.56	37.48	18.75	42.17	17.81	46.85	
		1560	21.18	39.78	20.37	44.75	19.43	49.72	
		1650	22.79	42.07	21.98	47.33	21.04	52.59	
		1750	24.59	44.62	23.78	50.20	22.84	55.77	
ASSW-150	6(150)	1180	18.97	38.80	17.61	43.65	16.42	48.49	15
		1250	20.59	41.10	19.23	46.23	18.04	51.37	
		1320	22.21	43.40	20.85	48.82	19.66	54.25	
		1390	23.83	45.70	22.47	51.41	21.28	57.12	
		1470	25.69	48.33	24.32	54.37	23.13	60.41	
ASSW-200A	8(200)	990	26.58	52.26	25.43	58.80	24.03	65.33	20
		1050	28.81	55.43	27.66	62.36	26.26	69.29	
		1110	31.04	58.60	29.89	65.92	28.49	73.25	
		1180	33.64	62.29	32.49	70.08	31.09	77.87	
		1250	36.24	65.99	35.09	74.24	33.70	82.48	
		1320	38.84	69.68	37.70	78.39	36.30	87.10	
		1390	41.44	73.38	40.30	82.55	38.90	91.72	

ASSW PERFORMANCE TABLE

NOTE: inlet flow rate $Q_s = m^3/min$

Model	Bore Inch (mm)	RPM	8000mmAq		9000mmAq		10000mmAq		Cooling Water Volume (L/min)
			Q_s	kw	Q_s	kw	Q_s	kw	
ASSW-200	8(200)	990	34.38	67.19	32.65	75.59	30.84	83.99	25
		1050	37.25	71.27	35.51	80.18	33.71	89.08	
		1110	40.12	75.34	38.38	84.76	36.58	94.17	
		1180	43.46	80.09	41.73	90.10	39.92	100.11	
		1250	46.81	84.84	45.07	95.45	43.27	106.05	
		1320	50.15	89.59	48.42	100.79	46.61	111.99	
		1390	53.50	94.34	51.76	106.14	49.96	117.93	
ASSW-250	10(250)	1050	51.94	95.02	50.36	106.90	48.32	118.78	25
		1110	55.76	100.45	54.18	113.01	52.15	125.57	
		1180	60.22	106.79	58.64	120.14	56.61	133.48	
		1250	64.68	113.12	63.10	127.26	61.07	141.40	
		1320	69.14	119.46	67.56	134.39	65.53	149.32	
		1390	73.60	125.79	72.02	141.52	69.99	157.24	
		1480	79.33	133.94	77.76	150.68	75.72	167.42	
ASSW-300	12(300)	600	55.28	111.50	52.93	125.44	50.60	139.38	30
		700	68.65	130.08	66.30	146.34	63.97	162.60	
		800	82.02	148.67	79.67	167.25	77.34	185.83	
		900	95.39	167.25	93.04	188.16	90.70	209.06	
		1000	108.75	185.83	106.41	209.06	104.07	232.29	
		1100	122.12	204.42	119.77	229.97	117.44	255.52	
		1200	135.49	223.00	133.14	250.88	130.81	278.75	
		1300	148.86	241.58	146.51	271.78	144.18	301.98	
		1400	162.23	260.17	159.88	292.69	157.55	325.21	

TRS PERFORMANCE TABLE

NOTE: inlet flow rate Qs=m³/min

Model	RPM	TYPE TRS-50 PERFORMANCE (ASSW-50 + ASSW-40)																				Cooling Water Volume (L/min)			
		10000mmAq		11000mmAq		12000mmAq		13000mmAq		14000mmAq		15000mmAq		16000mmAq		1700mmAq		18000mmAq		19000mmAq		2000mmAq		Air	Blower
		Qs	kw	Qs	kw	Qs	kw	Qs	kw	Qs	kw	Qs	kw	Qs	kw	Qs	kw	Qs	kw	Qs	kw	Qs	kw		
TRS-50	1250	1.61	4.61	1.53	5.07	1.45	5.53	1.41	5.99	1.37	6.45	1.35	6.91	1.32	7.37	1.27	7.83	1.21	8.29	1.18	8.75	1.14	9.21	160	8
	1350	1.87	4.98	1.82	5.48	1.77	5.97	1.72	6.47	1.66	6.96	1.62	7.47	1.58	7.97	1.53	8.46	1.47	8.96	1.44	9.45	1.40	9.95		
	1450	2.13	5.34	2.08	5.88	2.03	6.41	1.98	6.95	1.92	7.49	1.88	8.02	1.84	8.55	1.79	9.08	1.73	9.62	1.70	10.15	1.66	10.69		
	1550	2.39	5.71	2.34	6.28	2.29	6.85	2.24	7.43	2.18	8.00	2.14	8.57	2.10	9.14	2.05	9.71	1.99	10.28	1.95	10.85	1.92	11.42		
	1650	2.65	6.08	2.60	6.69	2.55	7.30	2.50	7.91	2.44	8.51	2.40	9.12	2.36	9.73	2.31	10.34	2.25	10.95	2.21	11.55	2.18	12.16		
	1750	2.91	6.45	2.86	7.10	2.81	7.74	2.76	8.39	2.70	9.03	2.66	9.68	2.62	10.32	2.57	10.96	2.51	11.61	2.47	12.25	2.44	12.90		
	1850	3.17	6.82	3.12	7.50	3.07	8.18	3.02	8.87	2.96	9.55	2.92	10.23	2.87	10.91	2.82	11.59	2.77	12.27	2.73	12.95	2.70	13.64		
	1950	3.43	7.19	3.38	7.91	3.32	8.62	3.27	9.34	3.22	10.06	3.18	10.78	3.13	11.50	3.08	12.22	3.03	12.94	2.99	13.65	2.95	14.37		

Model	RPM	TYPE TRS-65 PERFORMANCE (ASSW-65 + ASSW-50)																				Cooling Water Volume (L/min)			
		10000mmAq		11000mmAq		12000mmAq		13000mmAq		14000mmAq		15000mmAq		16000mmAq		1700mmAq		18000mmAq		19000mmAq		2000mmAq		Air	Blower
		Qs	kw	Qs	kw	Qs	kw	Qs	kw	Qs	kw	Qs	kw	Qs	kw	Qs	kw	Qs	kw	Qs	kw	Qs	kw		
TRS-65	1250	2.84	6.62	2.78	7.29	2.72	7.95	2.68	8.65	2.63	9.35	2.56	9.98	2.49	10.60	2.42	11.26	2.36	11.92	2.30	12.58	2.24	13.24	160	8
	1350	3.18	7.15	3.12	7.87	3.06	8.58	3.02	9.29	2.97	9.99	2.90	10.72	2.82	11.45	2.76	12.16	2.69	12.87	2.64	13.59	2.58	14.30		
	1450	3.52	7.68	3.46	8.45	3.39	9.22	3.35	9.94	3.30	10.65	3.23	11.47	3.16	12.29	3.10	13.06	3.03	13.83	2.97	14.60	2.92	15.36		
	1550	3.85	8.21	3.79	9.03	3.73	9.85	3.69	10.57	3.64	11.29	3.57	12.22	3.50	13.14	3.43	13.96	3.37	14.78	3.31	15.60	3.26	16.42		
	1650	4.19	8.74	4.13	9.62	4.07	10.49	4.03	11.27	3.98	12.05	3.91	13.02	3.83	13.99	3.77	14.86	3.71	15.73	3.65	16.61	3.59	17.48		

Model	RPM	TYPE TRS-80 PERFORMANCE (ASSW80 + ASSW-80)																				Cooling Water Volume (L/min)			
		10000mmAq		11000mmAq		12000mmAq		13000mmAq		14000mmAq		15000mmAq		16000mmAq		1700mmAq		18000mmAq		19000mmAq		2000mmAq		Air	Blower
		Qs	kw	Qs	kw	Qs	kw	Qs	kw	Qs	kw	Qs	kw	Qs	kw	Qs	kw	Qs	kw	Qs	kw	Qs	kw		
TRS-80	1200	4.66	12.76	4.51	14.03	4.36	15.30	4.16	16.58	3.95	17.86	3.74	19.14	3.53	20.42	3.35	21.69	3.18	22.96	3.01	24.24	2.84	25.51	160	16
	1300	5.26	13.82	5.11	15.20	4.96	16.58	4.76	17.96	4.55	19.34	4.34	20.73	4.13	22.12	3.95	23.50	3.78	24.88	3.61	26.26	3.44	27.64		
	1400	5.86	14.88	5.71	16.37	5.56	17.86	5.36	19.35	5.15	20.84	4.94	22.33	4.73	23.82	4.55	25.30	4.38	26.79	4.21	28.28	4.04	29.77		
	1500	6.45	15.94	6.31	17.54	6.16	19.14	5.96	20.73	5.75	22.32	5.54	23.92	5.33	25.52	5.15	27.11	4.98	28.70	4.81	30.30	4.64	31.89		
	1600	7.05	17.00	6.91	18.71	6.76	20.42	6.55	22.12	6.34	23.82	6.14	25.52	5.93	27.22	5.75	28.92	5.57	30.62	5.41	32.32	5.24	34.02		
	1650	7.35	17.54	7.21	19.29	7.06	21.04	6.85	22.80	6.64	24.56	6.44	26.31	6.23	28.06	6.05	29.82	5.87	31.57	5.70	33.33	5.54	35.08		
	1750	7.95	18.60	7.81	20.46	7.66	22.32	7.45	24.18	7.24	26.04	7.03	27.90	6.82	29.76	6.65	31.62	6.47	33.49	6.30	35.35	6.13	37.21		
	1850	8.55	19.66	8.41	21.63	8.26	23.60	8.05	25.57	7.84	27.54	7.63	29.50	7.42	31.46	7.25	33.43	7.07	35.40	6.90	37.37	6.73	39.33		
	1950	9.15	20.72	9.00	22.80	8.85	24.88	8.65	26.95	8.44	29.02	8.23	31.09	8.02	33.16	7.84	35.24	7.67	37.31	7.50	39.39	7.33	41.46		

Model	RPM	TYPE TRS-100 PERFORMANCE (ASSW-100 + ASSW-80)																				Cooling Water Volume (L/min)			
		10000mmAq		11000mmAq		12000mmAq		13000mmAq		14000mmAq		15000mmAq		16000mmAq		1700mmAq		18000mmAq		19000mmAq		2000mmAq		Air	Blower
		Qs	kw	Qs	kw	Qs	kw	Qs	kw	Qs	kw	Qs	kw	Qs	kw	Qs	kw	Qs	kw	Qs	kw	Qs	kw		
TRS-100	1200	7.31	15.31	7.24	16.84	7.17	18.37	7.00	19.90	6.83	21.43	6.76	22.96	6.69	24.49	6.56	26.02	6.43	27.55	6.32	29.09	6.20	30.62	160	18
	1300	8.15	16.58	8.08	18.24	8.01	19.90	7.84	21.56	7.67	23.21	7.60	24.87	7.53	26.53	7.40	28.19	7.27	29.85	7.16	31.51	7.04	33.17		
	1400	8.99	17.86	8.92	19.65	8.84	21.43	8.68	23.22	8.51	25.01	8.44	26.79	8.37	28.57	8.24	30.36	8.11	32.15	7.99	33.93	7.88	35.72		
	1500	9.82	19.13	9.75	21.05	9.68	22.96	9.52	24.88	9.35	26.79	9.28	28.70	9.21	30.62	9.08	32.53	8.95	34.44	8.83	36.36	8.72	38.27		

Model	RPM	TYPE TRS-125 PERFORMANCE (ASSW-125 + ASSW-125A)																				Cooling Water Volume (L/min)			
		10000mmAq		11000mmAq		12000mmAq		13000mmAq		14000mmAq		15000mmAq		16000mmAq		1700mmAq		18000mmAq		19000mmAq		2000mmAq		Air	Blower
		Qs	kw	Qs	kw	Qs	kw	Qs	kw	Qs	kw	Qs	kw	Qs	kw	Qs	kw	Qs	kw	Qs	kw	Qs	kw		
TRS-125	1100	14.25	29.52	13.94	32.48	13.62	35.43	13.59	38.38	13.56	41.33	13.24	44.28	12.92	47.24	12.51	50.19	12.11	53.14	11.64	56.09	11.17	59.05	250	24
	1180	15.69	31.67	15.38	34.84	15.06	38.00	15.03	41.17	15.00	44.34	14.68	47.51	14.35	50.67	13.95	53.84	13.55	57.01	13.08	60.17	12.61	63.34		
	1250	16.94	33.55	16.63	36.90	16.31	40.25	16.28	43.61	16.25	46.97	15.93	50.32	15.61	53.68	15.21	57.03	14.80	60.39	14.33	63.74	13.86	67.10		
	1320	18.20	35.43	17.89	38.97	17.57	42.51	17.54	46.06	17.51	49.60	17.19	53.14	16.87	56.68	16.46	60.23	16.06	63.77	15.59	67.31	15.12	70.85		
	1390	19.46	37.31	19.15	41.04	18.83	44.77	18.80	48.50	18.77	52.23	18.45	55.96	18.12	59.69	17.72	63.42	17.32	67.15	16.85	70.88	16.38	74.61		
	1470	20.89	39.46	20.58	43.40	20.26	47.34	20.23	50.93	20.20	54.52	19.88	58.82	19.56	63.13	19.16	67.07	18.75	71.02	18.28	74.96	17.81	78.91		
	1560	22.51	41.87	22.20	46.06	21.88	50.24	21.85	54.43	21.82	58.61	21.50	62.80	21.18	66.99	20.77	71.18	20.37	75.36	19.90	79.55	19.43	83.74		
	1650	24.12	44.28	23.81	48.71	23.50	53.14	23.47	57.57	23.43	62.00	23.11	66.43	22.79	70.85	22.39	75.28	21.98	79.71	21.51	84.14	21.04	88.57		
	1750	25.92	46.97	25.61	51.67	25.29	56.36	25.26	61.06	25.23	65.75	24.91	70.45	24.59	75.15	24.18	79.85	23.78	84.54	23.31	89.24	22.84	93.94		
	1850	27.71	49.65	27.40	54.62	27.09	59.59	27.06	64.55	27.02	69.51	26.70	74.48	26.38	79.44	25.98	84.41	25.57	89.37	25.10	94.34	24.64	99.30		

TRS PERFORMANCE TABLE

NOTE: inlet flow rate Qs=m³/min

Model	RPM	TYPE TRS-150 PERFORMANCE (ASSW-150 + ASSW-125A)																								Cooling Water Volume (L/min)	
		10000mmAq		11000mmAq		12000mmAq		13000mmAq		14000mmAq		15000mmAq		16000mmAq		1700mmAq		18000mmAq		19000mmAq		2000mmAq					
		Qs	kw	Qs	kw	Qs	kw	Qs	kw	Qs	kw	Qs	kw	Qs	kw	Qs	kw	Qs	kw	Qs	kw	Qs	kw	Air Blower			
TRS-150	1100	18.91	34.59	18.56	38.05	18.20	41.51	17.90	44.97	17.60	48.43	17.36	51.89	17.12	55.36	16.44	55.36	15.76	55.36	15.16	62.27	14.56	69.19	330	27		
	1180	20.77	37.12	20.41	40.83	20.05	44.54	19.75	48.25	19.45	51.96	19.21	55.67	18.97	59.38	18.29	59.38	17.61	59.38	17.01	66.80	16.42	74.23				
	1250	22.39	39.32	22.03	43.25	21.67	47.17	21.37	51.11	21.07	55.04	20.83	58.97	20.59	62.90	19.91	62.90	19.23	62.90	18.63	70.77	18.04	78.63				
	1320	24.01	41.51	23.65	45.67	23.29	49.82	22.99	53.97	22.69	58.12	22.45	62.27	22.21	66.43	21.53	66.43	20.85	66.43	20.25	74.73	19.66	83.03				
	1390	25.63	43.72	25.27	48.09	24.91	52.46	24.61	56.84	24.31	61.21	24.07	65.58	23.83	69.95	23.15	69.95	22.47	69.95	21.87	78.69	21.28	87.44				
	1470	27.48	46.24	27.12	50.86	26.76	55.48	26.47	60.11	26.17	64.73	25.93	69.35	25.69	73.97	25.00	73.97	24.32	73.97	23.73	83.22	23.13	92.47				

Model	RPM	TYPE TRS-200A PERFORMANCE (ASSW-200A + ASSW-200A)																								Cooling Water Volume (L/min)	
		10000mmAq		11000mmAq		12000mmAq		13000mmAq		14000mmAq		15000mmAq		16000mmAq		1700mmAq		18000mmAq		19000mmAq		2000mmAq					
		Qs	kw	Qs	kw	Qs	kw	Qs	kw	Qs	kw	Qs	kw	Qs	kw	Qs	kw	Qs	kw	Qs	kw	Qs	kw	Air Blower			
TRS-200A	990	28.10	65.33	27.76	71.86	27.41	78.39	27.24	84.93	26.73	91.46	26.37	97.99	26.00	104.52	25.72	111.06	25.43	117.59	24.73	124.12	24.03	130.66	400	40		
	1050	30.23	69.29	29.89	76.22	29.55	83.14	29.38	90.07	28.87	97.00	28.56	103.93	28.24	110.86	27.95	117.79	27.66	124.72	26.96	131.65	26.26	138.57				
	1110	32.37	73.25	32.03	80.57	31.69	87.90	31.52	95.22	31.01	102.54	30.67	109.87	30.32	117.19	30.11	124.52	29.89	131.84	29.19	139.17	28.49	146.49				
	1180	34.90	77.87	34.51	85.65	34.12	93.44	34.02	101.23	33.53	109.01	33.18	116.80	32.83	124.58	32.66	132.37	32.49	140.16	31.79	147.94	31.09	155.73				
	1250	37.33	82.48	36.99	90.73	36.64	98.98	36.52	107.23	36.06	115.48	35.74	123.73	35.41	131.98	35.25	140.22	35.09	148.47	34.40	156.72	33.70	164.97				
	1320	39.85	87.10	39.51	95.81	39.17	104.52	39.00	113.23	38.49	121.95	38.15	130.66	37.80	139.37	37.75	148.08	37.70	156.79	37.00	165.50	36.30	174.21				
	1390	42.28	91.72	41.94	100.90	41.60	110.07	41.48	119.24	41.02	128.41	40.67	137.58	40.31	146.76	40.30	155.93	40.30	165.10	39.60	174.27	38.90	183.45				

Model	RPM	Type TRS-200 performance (ASSW-200 + ASSW-200A)																								Cooling Water Volume (L/min)	
		10000mmAq		11000mmAq		12000mmAq		13000mmAq		14000mmAq		15000mmAq		16000mmAq		1700mmAq		18000mmAq		19000mmAq		2000mmAq					
		Qs	kw	Qs	kw	Qs	kw	Qs	kw	Qs	kw	Qs	kw	Qs	kw	Qs	kw	Qs	kw	Qs	kw	Qs	kw	Air Blower			
TRS-200	990	36.10	74.66	35.65	82.13	35.20	89.59	34.80	97.06	34.40	104.52	33.70	109.95	33.01	115.38	32.83	124.89	32.65	134.39	31.75	141.85	30.84	149.32	400	45		
	1050	38.90	79.19	38.45	87.10	38.00	95.02	37.60	102.94	37.20	110.86	36.48	116.74	35.76	122.62	35.64	132.58	35.51	142.53	34.61	150.45	33.71	158.37				
	1110	41.60	83.71	41.15	92.08	40.70	100.45	40.25	108.82	39.80	117.19	39.16	123.53	38.51	129.86	38.45	140.27	38.38	150.68	37.48	159.05	36.58	167.42				
	1180	44.80	88.99	44.35	97.89	43.90	106.79	43.50	115.69	43.10	124.58	42.41	131.11	41.72	137.63	41.73	148.91	41.73	160.18	40.83	169.08	39.92	177.98				
	1250	48.00	94.27	47.55	103.70	47.10	113.12	46.70	122.55	46.30	131.98	45.62	139.03	44.94	146.08	45.00	157.88	45.07	169.68	44.17	179.11	43.27	188.54				
	1320	51.20	99.55	50.75	109.50	50.30	119.46	49.90	129.41	49.50	139.37	48.82	146.95	48.15	154.52	48.28	166.85	48.42	179.18	47.52	189.14	46.61	199.09				
	1390	54.40	104.83	54.00	115.31	53.60	125.79	53.15	136.27	52.70	146.76	52.03	154.86	51.36	162.97	51.56	175.83	51.76	188.69	50.86	199.17	49.96	209.65				

Model	RPM	Type TRS-250 performance (ASSW-250 + ASSW-200)																								Cooling Water Volume (L/min)	
		10000mmAq		11000mmAq		12000mmAq		13000mmAq		14000mmAq		15000mmAq		16000mmAq		1700mmAq		18000mmAq		19000mmAq		2000mmAq					
		Qs	kw	Qs	kw	Qs	kw	Qs	kw	Qs	kw	Qs	kw	Qs	kw	Qs	kw	Qs	kw	Qs	kw	Qs	kw	Air Blower			
TRS-250	990	49.60	97.99	49.15	107.79	48.70	117.59	48.20	127.39	47.70	137.19	47.18	146.99	46.67	156.79	46.14	166.59	45.60	176.39	45.05	186.18	44.50	195.98	400	50		
	1050	53.30	103.93	52.80	114.32	52.30	124.72	51.85	135.11	51.40	145.50	50.89	155.90	50.38	166.29	49.86	176.68	49.35	187.08	48.84	197.47	48.32	207.86				
	1110	57.00	109.87	56.50	120.86	56.00	131.84	55.50	142.83	55.00	153.82	54.54	164.80	54.09	175.79	53.59	186.78	53.10	197.77	52.62	208.75	52.15	219.74				
	1180	61.30	116.80	60.80	128.48	60.30	140.16	59.80	151.84	59.30	163.52	58.86	175.20	58.41	186.88	57.94	198.56	57.47	210.24	57.04	221.92	56.61	233.60				
	1250	65.50	123.73	65.00	136.10	64.50	148.47	64.05	160.85	63.60	173.22	63.17	185.59	62.74	197.96	62.29	210.34	61.84	222.71	61.45	235.08	61.07	247.45				
	1320	69.80	130.66	69.30	143.72	68.80	156.79	68.35	169.85	67.90	182.92	67.48	195.98	67.07	209.05	66.64	222.11	66.21	235.18	65.87	248.25	65.53	261.31				
	1390	74.10	137.58	73.60	151.34	73.10	165.10	72.55	178.86	72.00	192.62	71.70	206.38	71.39	220.14	70.99	233.89	70.58	247.65	70.28	261.41	69.99	275.17				

Model	RPM	Type TRS-300 performance (ASSW-300 + ASSW-300)																								Cooling Water Volume (L/min)	
		10000mmAq		11000mmAq		12000mmAq		13000mmAq		14000mmAq		15000mmAq		16000mmAq		1700mmAq		18000mmAq		19000mmAq		2000mmAq					
		Qs	kw	Qs	kw	Qs	kw	Qs	kw	Qs	kw	Qs	kw	Qs	kw	Qs	kw	Qs	kw	Qs	kw	Qs	kw	Air Blower			
TRS-300	700	73.90	169.83	72.90	184.60	71.90	199.37	71.05	215.98	70.20	232.60	69.42	246.38	68.65	260.17	67.47	276.43	66.30	292.69	65.13	308.95	63.97	325.21	500	55		
	800	87.30	194.09	86.30	210.97	85.30	227.85	84.45	246.84	83.60	265.82	82.81	281.58	82.02	297.33	80.84	315.92	79.67	334.50	78.50	353.08	77.34	371.67				
	900	100.80	218.35	99.80	237.34	98.80	256.33	97.95	277.69	97.10	299.05	96.24	316.78	95.39	334.50	94.21	355.41	93.04	376.31	91.87	397.22	90.70	418.13				
	1000	114.10	242.62	113.10	263.71	112.10	284.81	111.25	308.54	110.40	332.28	109.58	351.97	108.75	371.67	107.58	394.90	106.41	418.13	105.24	441.36	104.07	464.58				
	1100	127.60	266.88	126.60	290.08	125.60	313.29	124.75	339.40	123.90	365.51	123.01	387.17	122.12	408.83	120.95	434.39	119.77	459.94	118.61	485.49	117.44	511.04				
	1200	141.00	291.14	140.00	316.46	139.00	341.77	138.15	370.25	137.30	398.73	136.40	422.37	135.49	446.00	134.32	473.88	133.14	501.75	131.98	529.63	130.81	557.50				
	1300	154.60	315.40	153.60	342.83	152.60	370.25	151.75	401.11	150.90	431.96	149.88	457.57	148.86	483.17	147.69	513.37	146.51	543.56	145.35	573.76	144.18	603.96				
	1400	166.49	339.66	165.42	369.20	164.34	398.73	163.42	431.96	162.51	465.19	162.37	492.76	162.23	520.33	161.05	552.86	159.88	585.38	158.71	617.90	157.55	650.42				

DIMENSION OF ACCESSORIES

Suction Silencer

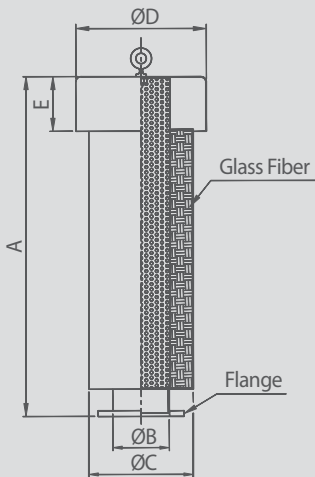

TYPE	A	ØB	ØC	ØD	E	Flange	fitting Model
SS32	112	32	26	156	36	1" PF	ASS-32
SS40	400	60	109	170	70	JIS 2" 5K	ASS-40
SS50	566	60	140	217	80	JIS 2" 10K	ASS-50
SS65	566	76	165	217	80	JIS 2 1/2" 10K	ASS-65
SS80	835	89	216	313	150	JIS 3" 10K	ASS-80
SS100	835	114	240	313	150	JIS 4" 10K	ASS-100
SS125	1321	140	280	395	185	JIS 5" 10K	ASS-125; ASS-125A
SS150	1321	165	300	395	185	JIS 6" 10K	ASS-150
SS200	1508	216	400	496	280	JIS 8" 10K	ASS-200; ASS-200A
SS250	1715	267	400	572	280	JIS 10" 10K	ASS-250
SS300A	1857	319	500	611	375	JIS 12" 10K	ASS-300A
SS300	1967	319	500	611	375	JIS 12" 10K	ASS-300
SS350	2237	356	550	676	425	JIS 14" 10K	ASS-350
SS400	2533	406	600	720	470	JIS 16" 10K	ASS-400

Discharge Silencer

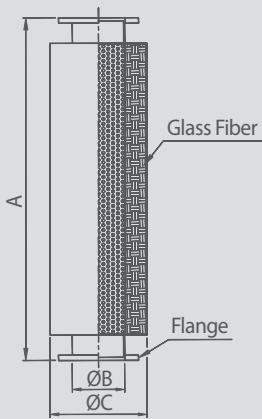

TYPE	A	ØB	ØC	Flange	fitting Model
DS50	589	60	140	JIS 2" 10K	ASS-40; ASS-50
DS65	589	76	165	JIS 2 1/2" 10K	ASS-65
DS80	789	89	216	JIS 3" 10K	ASS-80
DS100	789	114	240	JIS 4" 10K	ASS-100
DS125	1260	140	280	JIS 5" 10K	ASS-125; ASS-125A
DS150	1260	165	300	JIS 6" 10K	ASS-150
DS200	1640	216	400	JIS 8" 10K	ASS-200; ASS-200A
DS250	1760	267	400	JIS 10" 10K	ASS-250
DS300A	1750	319	500	JIS 12" 10K	ASS-300A
DS300	1850	319	500	JIS 12" 10K	ASS-300
DS350	2500	356	550	JIS 14" 10K	ASS-350
DS400	2700	406	600	JIS 16" 10K	ASS-400

Vacuum Filter Tank (for ASSV)

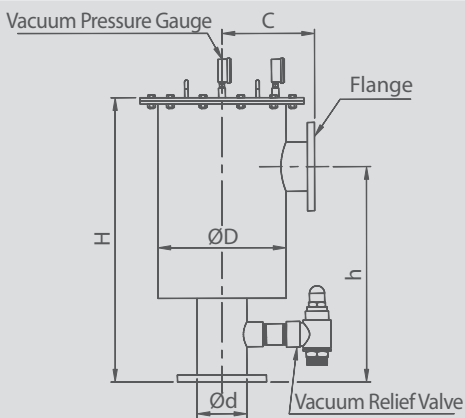

TYPE	H	h	C	ØD	Ød	Flange	fitting Model
FT40	657	459	202	244	60	JIS 2" 5K	ASSV-40
FT50	657	459	202	244	60	JIS 2" 10K	ASSV-50
FT65	657	459	202	244	76	JIS 2 1/2" 10K	ASSV-65
FT80	877	613	202	244	89	JIS 3" 10K	ASSV-80
FT100	877	613	202	244	114	JIS 4" 10K	ASSV-100
FT125	805	610	260	360	140	JIS 5" 10K	ASSV-125; ASSV-125A
FT150	925	690	260	360	165	JIS 6" 10K	ASSV-150
FT200	1075	770	310	470	216	JIS 8" 10K	ASSV-200; ASSV-200A
FT250	1200	900	310	470	267	JIS 10" 10K	ASSV-250
FT300	1350	1000	405	600	319	JIS 12" 10K	ASSV-300; ASSV-300A
FT350	1550	1150	455	700	356	JIS 14" 10K	ASSV-350
FT400	1750	1250	455	700	406	JIS 16" 10K	ASSV-400

Vacuum Relief Valve

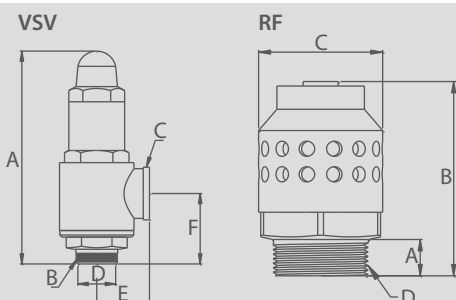

TYPE	A	B	C	D	E	F	fitting Model
VSV 1 1/4"	210	1 1/4"	1 1/4"	1 1/4"	51	70	ASSV-40, 50, 65, 80
VSV 2"	255	2"	2"	2"	67	89	ASSV-100, 125, 150, 200A, 200, 250

TYPE	A	B	C	D	fitting Model
RF 4"	35	168	128	4"	ASSV-300A, 300, 350, 400

DIMENSION OF ACCESSORIES

"T"-Joint

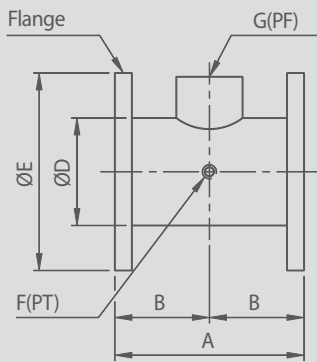

TYPE	A	B	ØD	ØE	G	F	Flange	fitting Model
HJ50	150	75	60	155	1¼"	¼"	JIS 2" 10K	ASS-40; ASS-50
HJ65	150	75	76	175	1¼"	¼"	JIS 2½" 10K	ASS-65
HJ80	180	90	89	185	1¼"	¼"	JIS 3" 10K	ASS-80
HJ100	180	90	114	210	2"	¼"	JIS 4" 10K	ASS-100
HJ125	250	125	140	250	2"	¼"	JIS 5" 10K	ASS-125; ASS-125A
HJ150	250	125	165	280	2"	¼"	JIS 6" 10K	ASS-150
HJ200	250	125	216	330	3"	¼"	JIS 8" 10K	ASS-200; ASS-200A
HJ250	250	125	267	400	3"	¼"	JIS 10" 10K	ASS-250
HJ300	300	150	319	445	3"	¼"	JIS 12" 10K	ASS-300; ASS-300A
HJ350	350	175	356	490	DN150	¼"	JIS 14" 10K	ASS-350
HJ400	350	175	406	560	DN150	¼"	JIS 16" 10K	ASS-400

Relief Valve

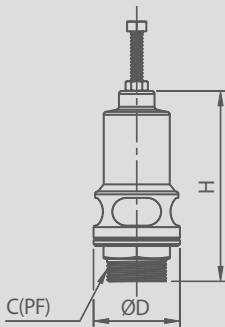

TYPE	H	ØD	C	fitting Model
PP ½"	182	72	1¼"	ASS-32
PP 1¼"	182	72	1¼"	ASS-40, 50, 65
PP 2"	192	85	2"	ASS-80, 100, 125A, 125, 150
PP 3"	231	115	3"	ASS-200A, 200, 250, 300A, 300
SD 150	292	225	DN150	ASS-350, 400

Check Valve

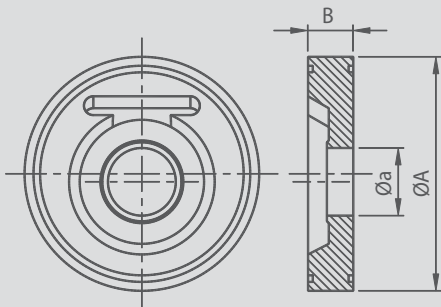

TYPE	ØA	Øa	B
ASS-40; ASS-50	101	26	20
ASS-65	124.5	36	24
ASS-80	133	45	24
ASS-100	157	65	22
ASS-125; ASS-125A	187	88	24
ASS-150	220	110	26
ASS-200; ASS-200A	269	138	27
ASS-250	330	186	28
ASS-300; ASS-300A	380	212	32
ASS-350	428	260	35
ASS-400	482	290	40

Vibration Isolator



Ø50mm x 75mm

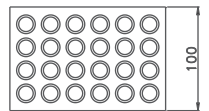

Fitting Model :
RSS-40,50,65,80,100

Fitting Model :
all RSS type

Sound-Proof (Optional)



1. The inside of sound proof use fiber glass and foaming material for making sure of good effect and outside material is made of SS41.
2. The sound proof can reduce the noise 15dB~20dB than before.
3. The outlet fan of sound proof can increase air circulation and remove heat.

AIRSPEC MARKETING SDN BHD
21 & 23, Jln 2/152, Taman Perindustrian OUG
Batu 6, Jln Puchong, 58200 Kuala Lumpur, Malaysia

TEL 603 7783 7082 (Hunting Line)
FAX 603 7785 4945
EMAIL marketing@airspec.com.my
WEB www.airspec.com.my

